

Image shown may not reflect
actual Engine

SPECIFICATIONS

I-6, 4-Stroke-Cycle-Diesel

Emissions.....	IMO
Displacement.....	14.64 L (893.39 in ³)
Rated Engine Speed.....	1800
Bore.....	137.2 mm (5.4 in)
Stroke.....	165.1 mm (6.5 in)
Aspiration.....	Turbocharged-Aftercooled
Governor.....	Mechanical
Cooling System.....	Heat Exchanger
Weight, Net Dry (approx.).....	1,470 kg (3,241 lb)
Refill Capacity	
Cooling System.....	94.5 L (25.0 gal)
Lube Oil System.....	34.0 L (9.0 gal)
Oil Change Interval.....	250 hrs
Caterpillar Diesel Engine Oil 10W30 or 15W40	
Rotation (from flywheel end).....	Counterclockwise
Flywheel and Flywheel Housing.....	SAE NO. 1
Flywheel Teeth.....	113

STANDARD ENGINE EQUIPMENT

Air Inlet System

Corrosion resistant aftercooler core, regular duty panel type air cleaner, turbocharger inlet

Cooling System

Gear driven self priming auxiliary sea water pump with rubber impeller, gear driven centrifugal jacket water pump, expansion tank, engine oil cooler, transmission oil cooler, thermostat and housing

Exhaust System

Watercooled exhaust manifold and turbocharger, round flanged outlet, dry elbow and flange

Fuel System

Fuel priming pump, fuel transfer pump, fuel filter - LH service, flexible fuel lines, fuel ratio control

Instrumentation

Heavy duty SAE standard rotation tachometer drive, LH instrument panel with engine oil pressure, water temperature, and fuel pressure gauges, service meter

Lube System

Crankcase breather, oil filter - RH service, oil level gauge - RH service, oil filler- RH service, manual oil sump pump

Mounting System

Front support

General

Vibration damper and guard, Caterpillar yellow paint, lifting eyes

ISO Certification

Factory-designed systems built at Caterpillar ISO 9001:2000 certified facilities

PERFORMANCE CURVES

B-RATING - DM6097-00

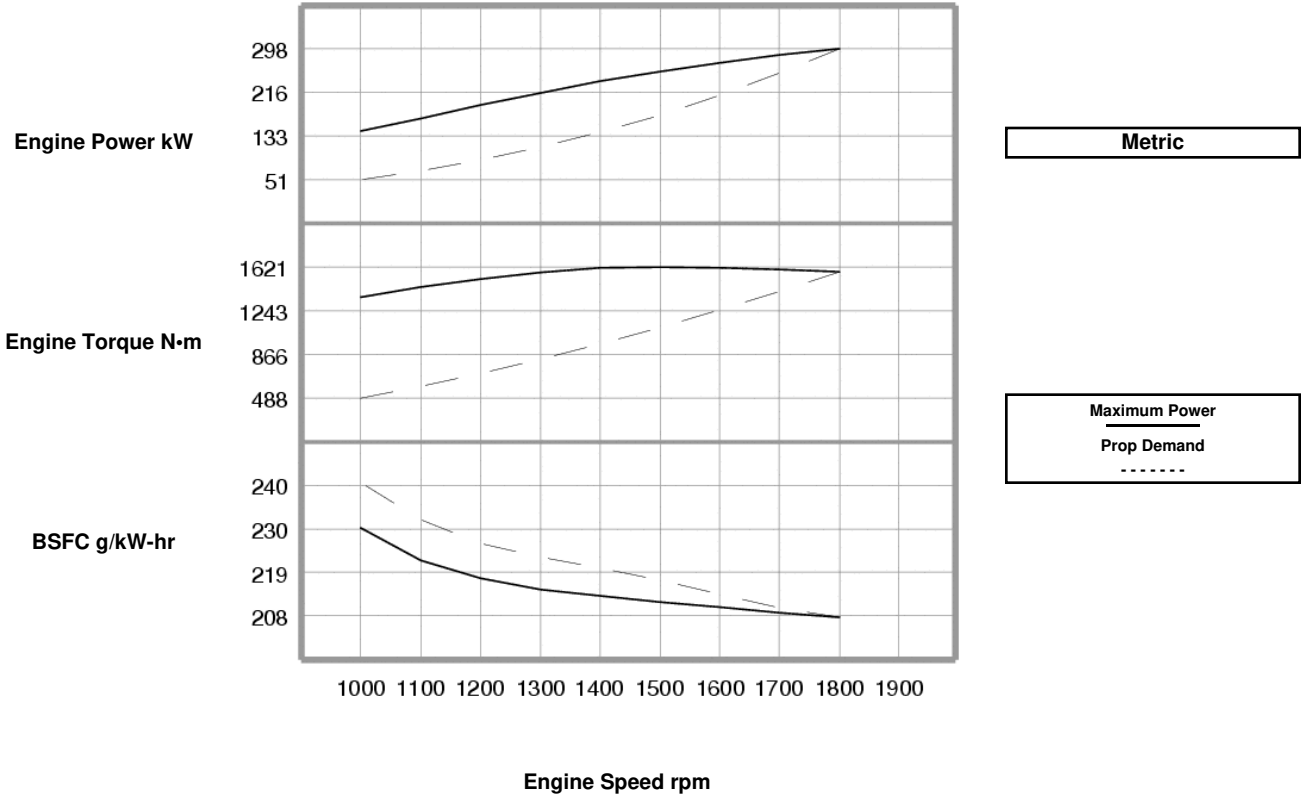

Maximum Power Data					Prop Demand Data				
Engine Speed rpm	Engine Power kW	Engine Torque N·m	BSFC g/kW-hr	Fuel Rate L/hr	Engine Speed rpm	Engine Power kW	Engine Torque N·m	BSFC g/kW-hr	Fuel Rate L/hr
1800	298	1581	208	73.9	1800	298	1581	208	73.9
1700	285	1602	209.2	71.1	1700	251	1410	210.3	62.9
1600	271	1616	210.4	67.9	1600	209.3	1249	213.6	53.3
1500	255	1621	211.7	64.3	1500	172.4	1098	216.9	44.6
1400	236	1610	213.1	59.9	1400	140.2	956	219.8	36.7
1300	214	1575	214.7	54.9	1300	112.3	825	222.5	29.8
1200	191	1521	217.2	49.5	1200	88.3	703	225.8	23.8
1100	167	1447	221.9	44.1	1100	68	590	231.4	18.8
1000	142	1360	229.5	39.0	1000	51.1	488	240.3	14.6

NOTE: Prop demand data is a cubic prop demand curve with 3.0 exponent for displacement hulls only.

PERFORMANCE CURVES

B-RATING - DM6097-00

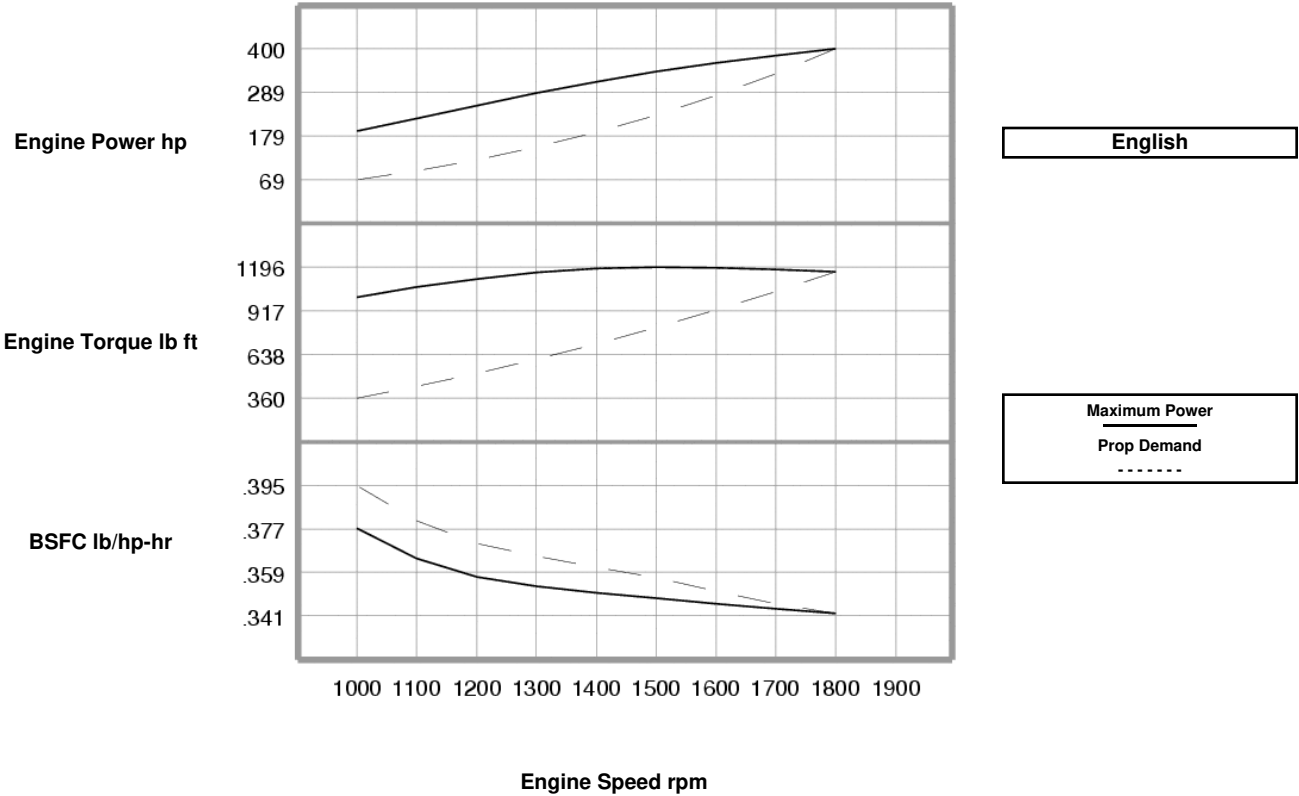

Maximum Power Data					Prop Demand Data				
Engine Speed rpm	Engine Power hp	Engine Torque lb ft	BSFC lb/hp-hr	Fuel Rate gph	Engine Speed rpm	Engine Power hp	Engine Torque lb ft	BSFC lb/hp-hr	Fuel Rate gph
1800	400	1166	.342	19.5	1800	400	1166	.342	19.5
1700	382	1182	.344	18.8	1700	337	1040	.346	16.6
1600	363	1192	.346	17.9	1600	281	921	.351	14.1
1500	341	1196	.348	17.0	1500	231	810	.357	11.8
1400	316	1187	.350	15.8	1400	188	705	.361	9.7
1300	288	1162	.353	14.5	1300	151	608	.366	7.9
1200	256	1122	.357	13.1	1200	118	519	.371	6.3
1100	224	1067	.365	11.6	1100	91	435	.380	5.0
1000	191	1003	.377	10.3	1000	69	360	.395	3.9

NOTE: Prop demand data is a cubic prop demand curve with 3.0 exponent for displacement hulls only.

RATING DEFINITIONS AND CONDITIONS

B Rating (Heavy Duty) –

% Load Factor: 40 to 80
% Time at Rated RPM: up to 40
Typical Time at Full Load: 10 hours out of 12
Typical Hour/Year: 3000 to 5000
Typical Applications: For vessels operating at rated load and rated speed up to 80% of the time with some load cycling (40% to 80% load factor). Typical applications could include but are not limited to vessels such as mid-water trawlers, purse seiner, crew and supply boats, ferries, or towboats. Typical operation ranges from 3000 to 5000 hours per year.

Power

at declared engine speed is in accordance with ISO3046-1:2002E. Caterpillar maintains ISO9001:1994/QS-9000 approved engine test facilities to assure calibration of test equipment. Electronically controlled engines are set at the factory at the advertised power corrected to standard ambient conditions. The published fuel consumption rates are in accordance with ISO3046-1:2002E.

Fuel rates

are based on fuel oil of 35° API [16°C (60°F)] gravity having an LHV of 42 780 kJ/kg (18,390 Btu/lb) when used at 29°C (85°F) and weighing 838.9 g/L (7.001 lb/U.S. gal). Additional ratings may be available for specific customer requirements. Consult your Caterpillar representative for additional information.

Performance data is calculated in accordance with tolerances and conditions stated in this specification sheet and is only intended for purposes of comparison with other manufacturer's engines. Actual engine performance may vary according to the particular application of the engine and operating conditions beyond Caterpillar's control.

Power produced at the flywheel will be within standard tolerances up to 49° C (120° F) combustion air temperature measured at the air cleaner inlet, and fuel temperature up to 52° C (125°F) measured at the fuel filter base. Power rated in accordance with NMMA procedure as crankshaft power. Reduce crankshaft power by 3% for propeller shaft power.

DIMENSIONS

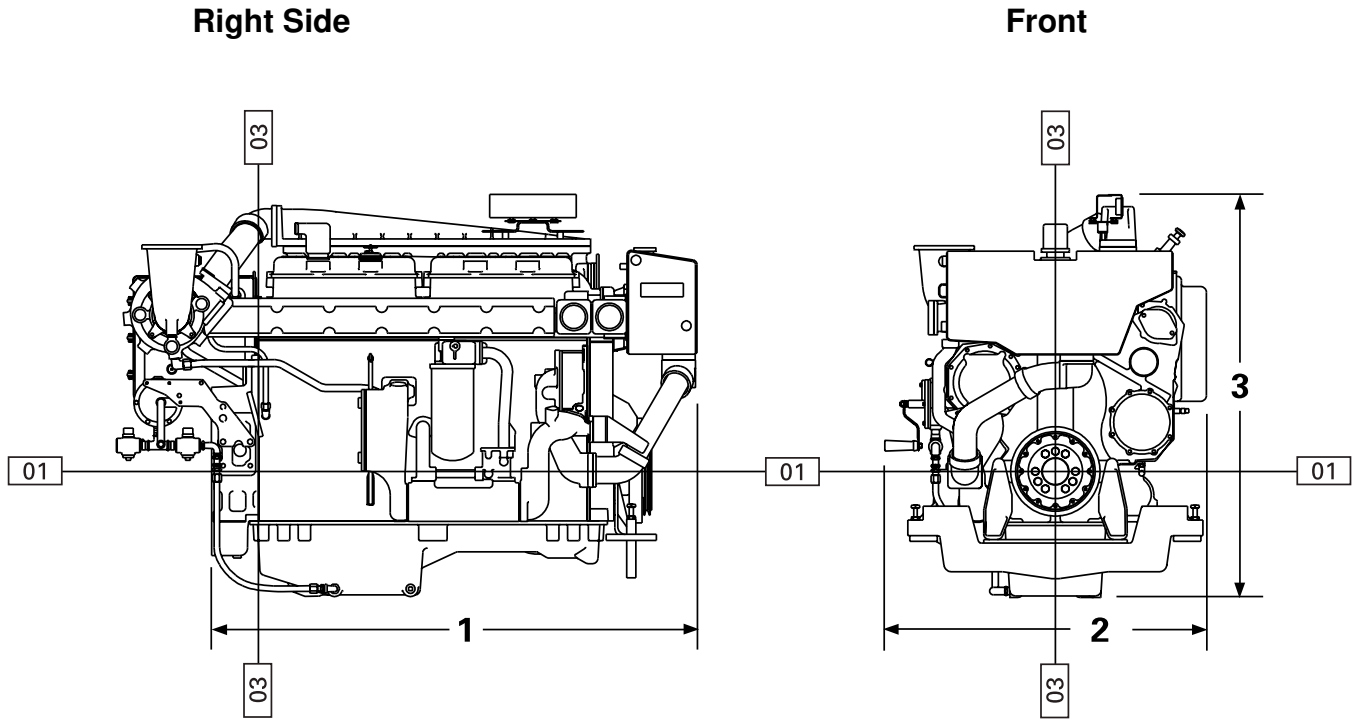

Engine Dimensions		
(1) Length to Flywheel Housing	1590.4 mm	62.61 in
(2) Width	1092.1 mm	43 in
(3) Height	1315.4 mm	51.79 in
Weight, Net Dry (approx)	1470 kg	3,241 lb

Note: Do not use for installation design. See general dimension drawings for detail (Drawing # 1806365).

Performance No.: DM6097-00

Feature Code: 406DM18

U.S. Sourced

7992998

29 September 2006

©2006 Caterpillar

All rights reserved.

Materials and specifications are subject to change without notice.

The International System of Units (SI) is used in this publication.

CAT, CATERPILLAR, their respective logos, "Caterpillar Yellow," and the POWER EDGE™ trade dress, as well as corporate and product identity used herein, are trademarks of Caterpillar and may not be used without permission.