

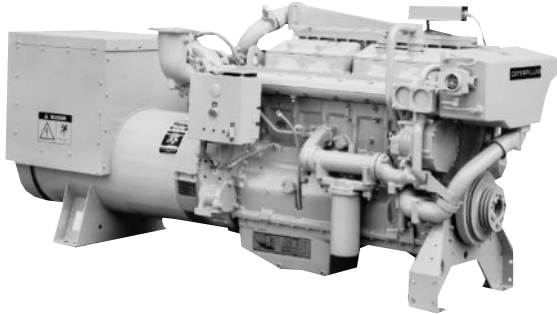

Marine Generator Set 3406C

215 ekW (269 kVA) 50 Hz @ 1500 rpm



Shown with Accessory Equipment

STANDARD EQUIPMENT

Air Inlet System

Corrosion resistant aftercooler core, regular duty panel type air cleaner

Cooling System

Gear driven self priming auxiliary sea water pump with rotary rubber impeller, gear driven centrifugal jacket water pump, oil cooler, expansion tank, thermostats and housing

Exhaust System

Watercooled manifold and turbocharger; dry elbow and flange, 152 mm (6 in.)

Flywheel and Flywheel Housing

SAE No. 1 (113 teeth)

Fuel System

LH fuel priming pump, fuel transfer pump, LH fuel filter, flexible fuel lines

Generator and Attachments

Brushless PM excited SR4 generator, VR3 voltage regulator, space heater

Instruments

LH instrument panel with oil pressure, water temperature, and fuel pressure gauges; service meter

Lube System

Crankcase breather, RH oil filter and oil level gauge, oil filler in valve cover

Mounting System

Rails, 85 mm (3.3 in.) height; linear vibration isolators between base and engine-generator

General

Vibration damper, Caterpillar yellow paint, lifting eyes

SPECIFICATIONS

I-6, 4-Stroke-Cycle-Diesel

Emissions IMO compliant
 Displacement 14.6 L (893 cu. in.)
 Bore 137 mm (5.4 in.)
 Stroke 165 mm (6.5 in.)
 Aspiration Turbocharged-Aftercooled
 Governor Hydra-mechanical or PSG
 Engine Weight, Net Dry (approx) 2404 kg (5300 lb)
 Capacity for Liquids
 Cooling System (engine only) 34 L (9 U.S. gal)
 Lube Oil System (refill) 34 L (9 U.S. gal)
 Oil Change Interval 250 hr
 Caterpillar DEO 10W30 or 15W40
 Rotation (from flywheel end) Counterclockwise

ACCESSORY EQUIPMENT

Air Starting Motor
 Alarm Contactor — Oil Pressure, Water Temperature
 24V 35 Amp, 60 Amp Alternator
 Auxiliary Drive Pulley
 Auxiliary Water Pump
 Crankshaft Pulley
 Deep Sump Oil Pan
 Digital Tachometer
 Double Wall Fuel Lines and Drain
 Dry Charge Coolant Conditioner
 Duplex Fuel Filters
 12V, 24V, 32V Electric Gauges
 Electric Shutoffs — Oil Pressure, Water Temperature, Overspeed
 24V Electric Starting Motor
 Ether Starting Aid
 Exhaust Elbow, Pipe, Flexible Fittings
 Extension Terminal Box
 24V Governor Control Motor and Switch
 Heat Exchanger and Expansion Tank
 4- or 8-Hole Instrument Panel
 Load Sharing or Speed Control Governor
 Low Voltage Connections
 Magnetic Pickup
 Manual Voltage Control
 Mechanical Shutoff — Oil Pressure, Water Temperature
 Mechanical Tachometer Drive
 Paralleling Kit
 Primary Fuel Filter/Water Separator
 RFI Filter
 Solenoid Shutoff — 24V ETR, ETS
 Spare Parts Kit
 Terminal Strip Connections

PERFORMANCE DATA

Turbocharged-Aftercooled

DM6102-00

215 ekW (.8 pf) 269 kVA			
% load	ekW	Lph	gph
100	215	59.2	15.6
75	161	44.9	11.9
50	108	31.3	8.3
25	54	18.7	4.9

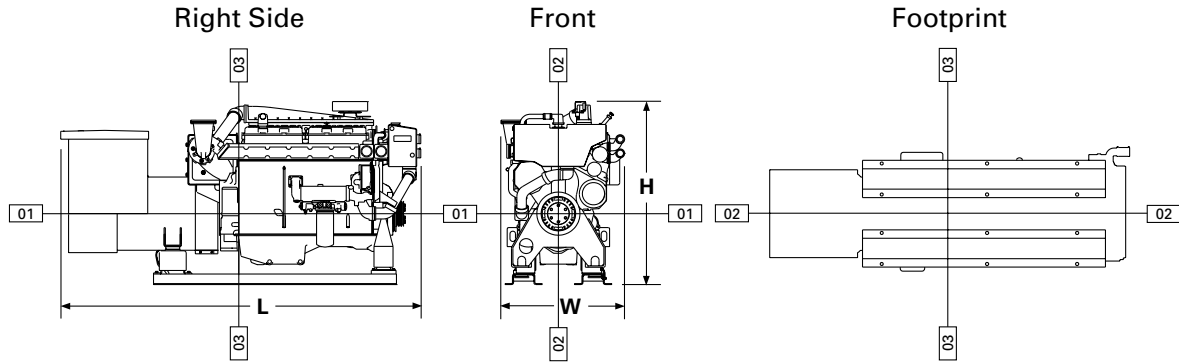

DIMENSIONS*

	mm	in.				
Overall Length	2902.7	114.3				
Length from front to rear face of block	1467.7	57.8				
Length from rear face of block to back of generator	1435.0	56.5				
Overall Height	1474.2	58.0				
Height from crankshaft centerline to top of engine	903.2	35.6				
Height from crankshaft centerline to bottom of rails	571.0	22.5				
Overall Width	996.3	39.2				
Width from crankshaft centerline to port side	533.7	21.0				
Width from crankshaft centerline to starboard side	462.6	18.2				
			Front	Center	Rear	
	mm	in.	mm	in.	mm	in.
Customer mounting hole diameter	25.5	1.0	25.5	1.0	25.5	1.0
Width from crankshaft centerline to side	154.9	6.1	154.9	6.1	154.9	6.1
	404.9	15.9	404.9	15.9	404.9	15.9
Length from rear face of block to mounting holes	1043.1	41.1	317.1	12.5	531.9	20.9

*Illustrations and dimensions from drawing: 180-6358.

CATERPILLAR SR4 GENERATOR

- Type Brushless, revolving field, solid state self-excited
- Construction Single bearing, close coupled
- Three-phase 10 wire, wye
- Insulation Class F with tropicalization and anti-abrasion
- Alignment Pilot Shaft
- Voltage Regulator Generator mounted, volts-per-hertz
- Voltage Droop Adjustable for parallel operation
- Voltage Regulation ±1/2%
- Voltage Gain Adjustable
- Generator Weight, Net (approx).
 449 frame 957 kg (2109 lb)
- Space Heater
- Voltages Available (adjustable +10%, -5%)
 50 Hz — 190-380 volts
- Meets or exceeds Marine Society requirements

RATING CONDITIONS

- Engine Performance Parameters**
- Power ±3%
 - Specific Fuel Consumption ±3%
 - Fuel Rate ±5%
- Ratings** are based on SAE J1228/ISO8665 standard conditions of 100 kPa (29.61 in. Hg), 25°C (77°F), and 30% relative humidity. These ratings also apply at ISO3046/1, DIN6271/3, and BS5514 conditions of 100 kPa (29.61 in. Hg), 27°C (81°F), and 60% relative humidity.
- Fuel rates** are based on fuel oil of 35° API [16°C (60°F)] gravity having an LHV of 42 780 kJ/kg (18,390 Btu/lb) when used at 29°C (85°F) and weighing 838.9 g/L (7.001 lb/U.S. gal).
- Additional ratings may be available for specific customer requirements. Consult your Caterpillar representative for additional information.

Performance data is calculated in accordance with tolerances and conditions stated in this specification sheet and is only intended for purposes of comparison with other manufacturers' engines. Actual engine performance may vary according to the particular application of the engine and operating conditions beyond Caterpillar's control.