

60 Hz, 1800 rpm
Radiator Cooled

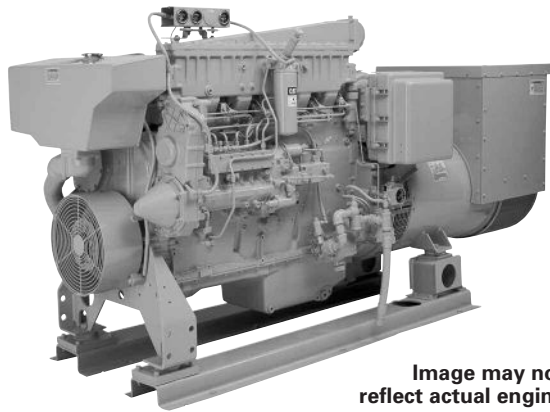

Image may not reflect actual engine

CATERPILLAR® ENGINE SPECIFICATIONS

I-6, 4-Stroke-Cycle-Diesel

Emissions IMO Compliant
 Displacement 14.6 L (893 cu. in.)
 Bore 137 mm (5.4 in.)
 Stroke 165 mm (6.5 in.)
 Aspiration Turbocharged-Aftercooled
 Governor Hydra-mechanical or PSG
 Engine Weight, Net Dry (approx).... 1435 kg (3165 lb)
 Capacity for Liquids
 Cooling System (engine only).. 93 L (24.75 U.S. gal)
 Lube Oil System (refill)..... 34 L (9 U.S. gal)
 Oil Change Interval 250 hr
 Caterpillar DEO 10W30 or 15W40
 Rotation (from flywheel end)..... Counterclockwise

STANDARD EQUIPMENT

Air Inlet System

Corrosion resistant aftercooler core, regular duty panel type air cleaner

Cooling System

Engine mounted radiator, blower fan, fan drive, fan guard

Exhaust System

Watercooled manifold and turbocharger; dry elbow and flange, 152 mm (6 in.)

Flywheel and Flywheel Housing

SAE No. 1 (113 teeth)

Fuel System

LH fuel priming pump, fuel transfer pump, LH fuel filter, flexible fuel lines

Generator and Attachments

Brushless PM excited SR4 generator, VR3 voltage regulator, space heater

Instruments

RH instrument panel with oil pressure, water temperature, and fuel pressure gauges; service meter

Lube System

Crankcase breather, RH oil filter and oil level gauge, oil filler in valve cover

Mounting System

Rails, 85 mm (3.3 in.) height; linear vibration isolators between base and engine-generator

General

Vibration damper, Caterpillar yellow paint, lifting eyes

ACCESSORY EQUIPMENT

Air Starting Motor
 Alarm Contactor — Oil Pressure, Water Temperature
 24V 35 Amp, 60 Amp Alternator
 Auxiliary Drive Pulley
 Crankshaft Pulley
 Deep Sump Pump Oil Pan
 Digital Tachometer
 Double Wall Fuel Lines and Drain
 Duplex Fuel Filters
 12V, 24V, 32V Electric Gauges
 Electric Shutoffs — Oil Pressure, Water Temperature, Overspeed
 24V Electric Starting Motor
 Ether Starting Aid
 Exhaust Elbow, Pipe, Flexible Fittings
 Extension Terminal Box
 24V Governor Control Motor and Switch
 4- or 8- Hole Instrument Panel
 Load Sharing or Speed Control Governor
 Low Voltage Connections
 Magnetic Pickup
 Manual Voltage Control
 Mechanical Shutoff — Oil Pressure, Water Temp.
 Mechanical Tachometer Drive
 Paralleling Kit
 Primary Fuel Filter/Water Separator
 RFI Filter
 Solenoid Shutoff — 24V ETR, ETS
 Spare Parts Kit
 Terminal Strip Connections

PERFORMANCE DATA

Turbocharged-Aftercooled

DM6105-00

250 ekW (.8 pf) 313 kVA			
% load	ekW	Lph	gph
100	260	72.6	19.2
75	195	54.5	14.4
50	130	38.3	10.1
25	65	23.4	6.2

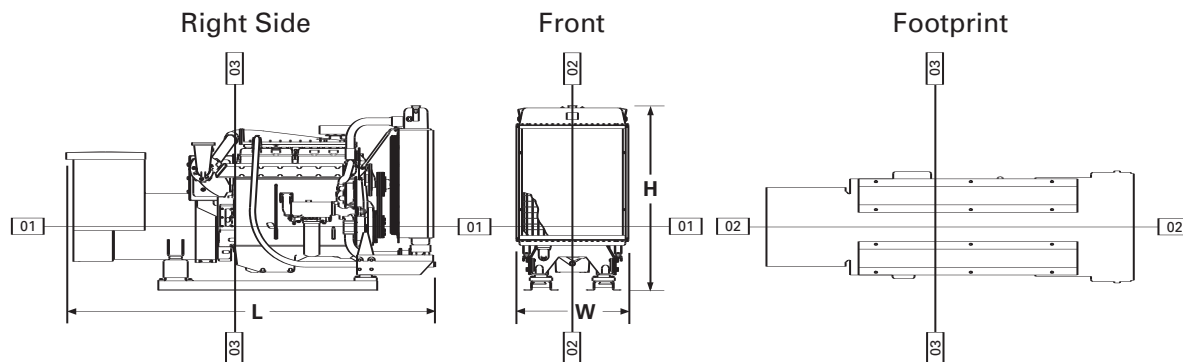

DIMENSIONS*

	mm	in.				
Overall Length	3285.7	129.4				
Length from front to rear face of block	1774.5	69.9				
Length from rear face of block to back of generator	1511.2	59.5				
Overall Height	1653.8	65.1				
Height from crankshaft centerline to top of engine	1082.8	42.6				
Height from crankshaft centerline to bottom of rails	571.0	22.5				
Overall Width	1001.8	39.4				
Width from crankshaft centerline to port side	500.9	19.7				
Width from crankshaft centerline to starboard side	500.9	19.7				
			Front	Center	Rear	
			mm	in.	mm	in.
Customer mounting hole diameter	20.5	0.8	20.5	0.8	20.5	0.8
Width from crankshaft centerline to side	154.9	6.1	154.9	6.1	154.9	6.1
	404.9	15.9	404.9	15.9	404.9	15.9
Length from rear face of block to mounting holes	1043.1	41.1	317.1	12.5	531.9	20.9

*Illustrations and dimensions from drawing: 180-6347.

CATERPILLAR SR4 GENERATOR

Type Brushless, revolving field, solid state self-excited
 Construction Single bearing, close coupled
 Three-phase 10 wire, wye
 Insulation Class F with tropicalization and anti-abrasion
 Alignment Pilot Shaft
 Voltage Regulator Generator mounted, volts-per-hertz
 Voltage Regulation ±1/2%
 Voltage Droop Adjustable for parallel operation
 Voltage Gain Adjustable
 Generator Weight, Net (approx)
 449 frame 957 kg (2109 lb)
 Space Heater
 Voltages Available (adjustable +10%, -5%)
 60 Hz — 220-440 volts
 Meets or exceeds Marine Society requirements

RATING CONDITIONS

Engine Performance Parameters
 Power ±3%
 Specific Fuel Consumption ±3%
 Fuel Rate ±5%

Ratings are based on SAE J1228/ISO8665 standard conditions of 100 kPa (29.61 in. Hg), 25°C (77°F), and 30% relative humidity. These ratings also apply at ISO3046/1, DIN6271/3, and BS5514 conditions of 100 kPa (29.61 in. Hg), 27°C (81°F), and 60% relative humidity.

Fuel rates are based on fuel oil of 35° API [16°C (60°F)] gravity having an LHV of 42 780 kJ/kg (18,390 Btu/lb) when used at 29°C (85°F) and weighing 838.9 g/L (7.001 lb/U.S. gal).

Additional ratings may be available for specific customer requirements. Consult your Caterpillar representative for additional information.

Performance data is calculated in accordance with tolerances and conditions stated in this specification sheet and is only intended for purposes of comparison with other manufacturers' engines. Actual engine performance may vary according to the particular application of the engine and operating conditions beyond Caterpillar's control.

CAT, CATERPILLAR, their respective logos, "Caterpillar Yellow" and the POWER EDGE trade dress, as well as corporate and product identity used herein, are trademarks of Caterpillar and may not be used without permission.