

Image may not reflect actual engine

CATERPILLAR® ENGINE SPECIFICATIONS

I-6, 4-Stroke-Cycle-Diesel

Emissions IMO Compliant
 Displacement 14.6 L (893 cu. in.)
 Bore 137 mm (5.4 in.)
 Stroke 165 mm (6.5 in.)
 Aspiration Turbocharged-Aftercooled
 Governor PSG
 Engine Weight, Net Dry (approx) . . . 2404 kg (5300 lb)
 Capacity for Liquids
 Cooling System (engine only) . . . 20.8 L (5.5 U.S. gal)
 Lube Oil System (refill) 68 L (18 U.S. gal)
 Oil Change Interval 250 hr
 Caterpillar DEO 10W30 or 15W40
 Rotation (from flywheel end) Counterclockwise

STANDARD EQUIPMENT

Air Inlet System

Corrosion resistant aftercooler core, regular duty panel type air cleaner

Alarm and Protection System

Magnetic pickup, remote alarm and protection panel, sensors wired to package-mounted junction box

Cooling System

Gear driven self priming auxiliary sea water pump with rotary rubber impeller, gear driven centrifugal jacket water pump, oil cooler, expansion tank, thermostats and housing

Exhaust System

Watercooled manifold and turbocharger; dry elbow and flange, 152 mm (6 in.)

Flywheel and Flywheel Housing

SAE No. 1 (113 teeth)

Fuel System

LH fuel priming pump, fuel transfer pump, LH duplex fuel filter, minimized flexible fuel lines, double wall fuel lines and drain

Generator and Attachments

Brushless PM excited SR4 generator, VR3 voltage regulator, space heater

Instruments

LH instrument panel with oil pressure, water temperature, service meter

Lube System

Crankcase breather, RH oil filter and oil level gauge, oil filler in valve cover, deep sump oil pan

Mounting System

Rails, 85 mm (3.3 in.) height, linear vibration isolators between base and engine-generator

General

Vibration damper, Caterpillar yellow paint, lifting eyes

ACCESSORY EQUIPMENT

Air Starting Motor
 24V 35 Amp, 60 Amp Alternator
 Auxiliary Drive Pulley
 Crankshaft Pulley
 Duplex Oil Filter, RH
 24V Electric Starting Motor
 Ether Starting Aid
 Exhaust Elbow, Pipe, Flexible Fittings
 Extension Terminal Box
 Load Sharing or Speed Control Governor
 Low Voltage Connections
 Manual Voltage Control
 Paralleling Kit
 Primary Fuel Filter/Water Separator
 RFI Filter
 Solenoid Shutoff — 24V ETR, ETS
 Spare Parts Kit
 Terminal Strip Connections

PERFORMANCE DATA

Turbocharged-Aftercooled

DM6105-00

260 ekW (.8 pf) 325 kVA			
% load	ekW	Lph	gph
100	260	72.6	19.2
75	195	54.5	14.4
50	130	38.3	10.1
25	65	23.4	6.2

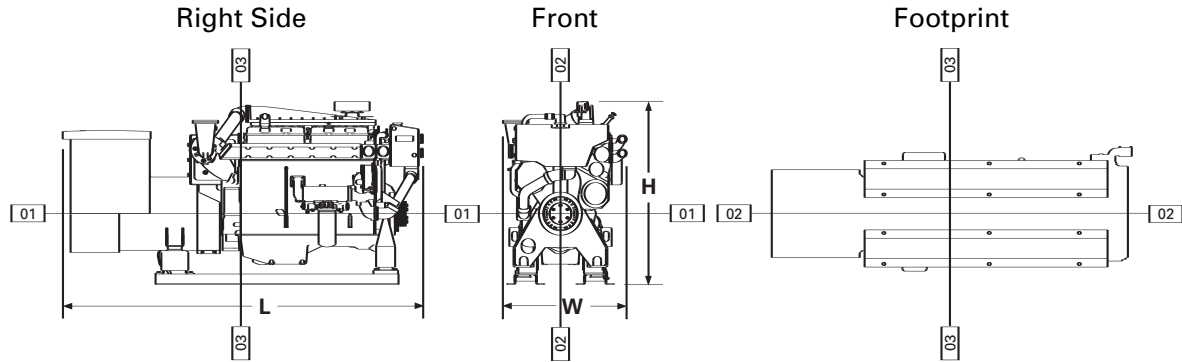

DIMENSIONS

	mm	in.				
Overall Length	2902.7	114.3				
Length from front to rear face of block	1467.7	57.8				
Length from rear face of block to back of generator	1435.0	56.5				
Overall Height	1474.2	58.0				
Height from crankshaft centerline to top of engine	903.2	35.6				
Height from crankshaft centerline to bottom of rails	571.0	22.5				
Overall Width	996.3	39.2				
Width from crankshaft centerline to port side	533.7	21.0				
Width from crankshaft centerline to starboard side	462.6	18.2				
			Front	Center	Rear	
	mm	in.	mm	in.	mm	in.
Customer mounting hole diameter	25.5	1.0	25.5	1.0	25.5	1.0
Width from crankshaft centerline to side	154.9	6.1	154.9	6.1	154.9	6.1
	404.9	15.9	404.9	15.9	404.9	15.9
Length from rear face of block to mounting holes	1043.1	41.1	317.1	12.5	531.9	20.9

CATERPILLAR SR4 GENERATOR

- Type Brushless, revolving field, solid state self-excited
- Construction Single bearing, close coupled
- Three-phase..... 10 wire, wye
- Insulation..... Class F with tropicalization and anti-abrasion
- Alignment..... Pilot Shaft
- Voltage Regulator Generator mounted, volts-per-hertz
- Voltage Droop Adjustable for parallel operation
- Voltage Regulation..... ±1/2%
- Voltage Gain Adjustable
- Generator Weight, Net (approx)
449 frame..... 957 kg (2109 lb)
- Space Heater
- Voltages Available (adjustable +10%, -5%)
60 Hz — 220-440 volts
- Meets or exceeds Marine Society requirements

RATING CONDITIONS

- Engine Performance Parameters**
- Power..... ±3%
 - Specific Fuel Consumption ±3%
 - Fuel Rate..... ±5%

Ratings are based on SAE J1228/ISO8665 standard conditions of 100 kPa (29.61 in. Hg), 25°C (77°F), and 30% relative humidity. These ratings also apply at ISO3046/1, DIN6271/3, and BS5514 conditions of 100 kPa (29.61 in. Hg), 27°C (81°F), and 60% relative humidity.

Fuel rates are based on fuel oil of 35° API [16°C (60°F)] gravity having an LHV of 42 780 kJ/kg (18,390 Btu/lb) when used at 29°C (85°F) and weighing 838.9 g/L (7.001 lb/U.S. gal).

Additional ratings may be available for specific customer requirements. Consult your Caterpillar representative for additional information.

Performance data is calculated in accordance with tolerances and conditions stated in this specification sheet and is only intended for purposes of comparison with other manufacturers' engines. Actual engine performance may vary according to the particular application of the engine and operating conditions beyond Caterpillar's control.

CAT, CATERPILLAR, their respective logos, "Caterpillar Yellow" and the POWER EDGE trade dress, as well as corporate and product identity used herein, are trademarks of Caterpillar and may not be used without permission.