

Image shown may not reflect
actual Engine

SPECIFICATIONS

I-6, 4-Stroke-Cycle-Diesel

Emissions.....	IMO
Displacement.....	14.64 L (893.39 in ³)
Rated Engine Speed.....	1800
Bore.....	137.2 mm (5.4 in)
Stroke.....	165.1 mm (6.5 in)
Aspiration.....	Turbocharged-Aftercooled
Governor.....	Mechanical
Cooling System.....	Heat Exchanger
Weight, Net Dry (approx.).....	1,402 kg (3,091 lb)
Refill Capacity	
Cooling System.....	94.5 L (25.0 gal)
Lube Oil System.....	34.0 L (9.0 gal)
Oil Change Interval.....	250 hrs
Caterpillar Diesel Engine Oil 10W30 or 15W40	
Rotation (from flywheel end).....	Counterclockwise
Flywheel and Flywheel Housing.....	SAE NO. 1
Flywheel Teeth.....	113

STANDARD ENGINE EQUIPMENT

Air Inlet System

Corrosion resistant aftercooler core, regular duty panel type air cleaner, turbocharger inlet

Cooling System

Gear driven self priming auxiliary sea water pump with rubber impeller, gear driven centrifugal jacket water pump, expansion tank, engine oil cooler, transmission oil cooler, thermostat and housing

Exhaust System

Watercooled exhaust manifold and turbocharger, round flanged outlet, dry elbow and flange

Fuel System

Fuel priming pump, fuel transfer pump, fuel filter - LH service, flexible fuel lines, fuel ratio control

Instrumentation

Heavy duty SAE standard rotation tachometer drive, LH instrument panel with engine oil pressure, water temperature, and fuel pressure gauges, service meter

Lube System

Crankcase breather, oil filter - RH service, oil level gauge - RH service, oil filler- RH service, manual oil sump pump

Mounting System

Front support

General

Vibration damper and guard, Caterpillar yellow paint, lifting eyes

ISO Certification

Factory-designed systems built at Caterpillar ISO 9001:2000 certified facilities

PERFORMANCE CURVES

B-RATING - DM6094-01

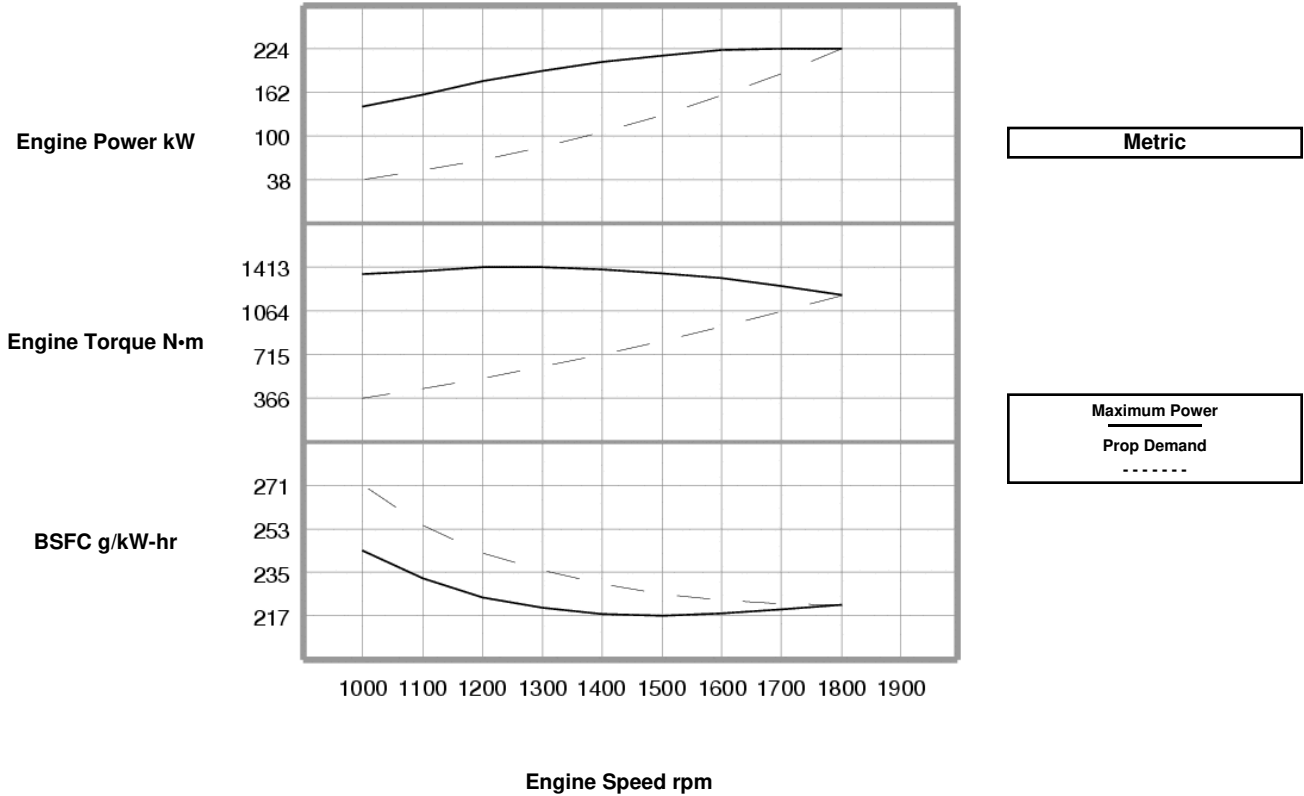

Maximum Power Data					Prop Demand Data				
Engine Speed rpm	Engine Power kW	Engine Torque N·m	BSFC g/kW-hr	Fuel Rate L/hr	Engine Speed rpm	Engine Power kW	Engine Torque N·m	BSFC g/kW-hr	Fuel Rate L/hr
1800	224	1188	221.4	59.1	1800	223.3	1185	221.5	59.0
1700	224	1260	219.5	58.7	1700	188.1	1057	222	49.8
1600	222	1323	217.9	57.6	1600	156.9	936	223.4	41.8
1500	214	1363	216.9	55.4	1500	129.2	823	226	34.8
1400	205	1397	217.8	53.2	1400	105.1	717	230.2	28.8
1300	192	1410	220.3	50.4	1300	84.1	618	235.8	23.7
1200	178	1413	224.6	47.5	1200	66.2	527	243.3	19.2
1100	159	1380	232.3	44.0	1100	51	442	254.7	15.5
1000	142	1355	244.1	41.3	1000	38.3	366	271.3	12.4

NOTE: Prop demand data is a cubic prop demand curve with 3.0 exponent for displacement hulls only.

PERFORMANCE CURVES

B-RATING - DM6094-01

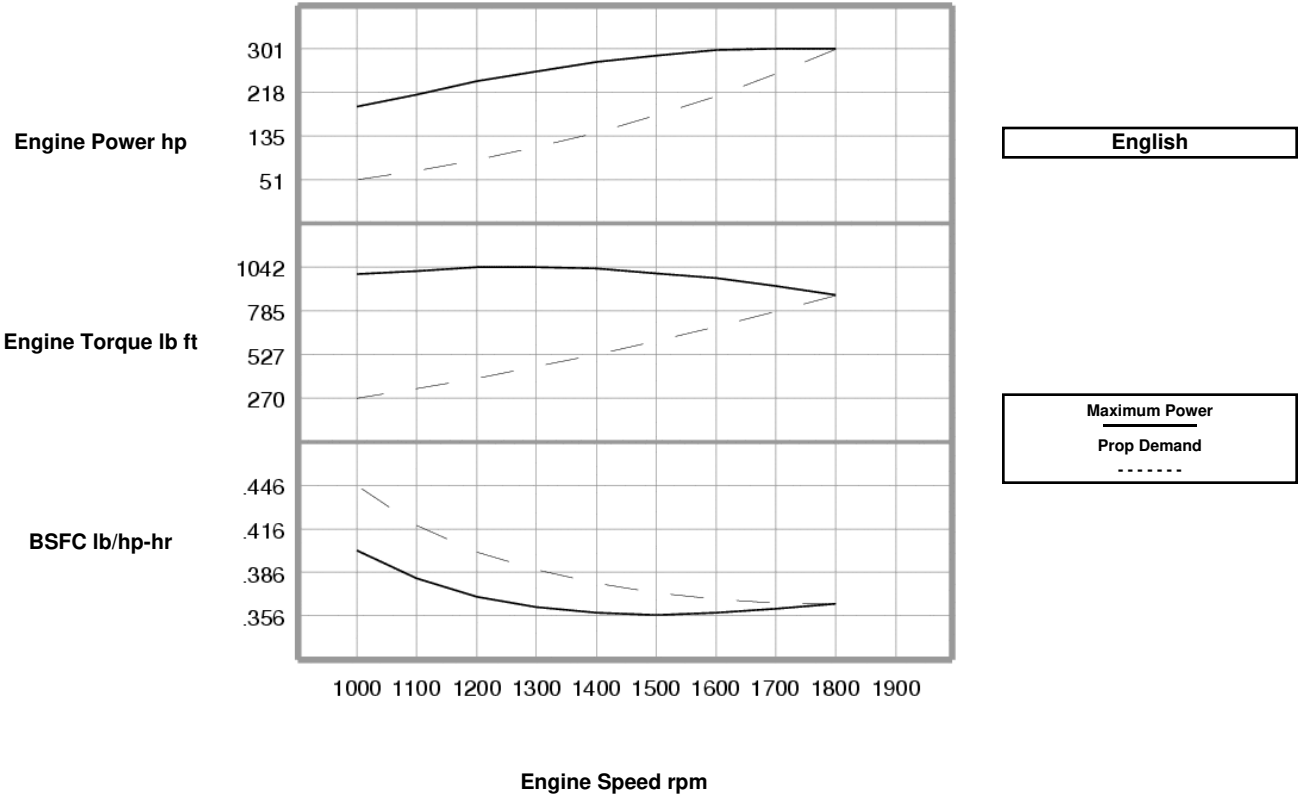

Maximum Power Data					Prop Demand Data				
Engine Speed rpm	Engine Power hp	Engine Torque lb ft	BSFC lb/hp-hr	Fuel Rate gph	Engine Speed rpm	Engine Power hp	Engine Torque lb ft	BSFC lb/hp-hr	Fuel Rate gph
1800	300	876	.364	15.6	1800	299	874	.364	15.6
1700	301	929	.361	15.5	1700	252	780	.365	13.2
1600	297	976	.358	15.2	1600	210	690	.367	11.0
1500	287	1005	.357	14.6	1500	173	607	.372	9.2
1400	275	1030	.358	14.1	1400	141	529	.378	7.6
1300	257	1040	.362	13.3	1300	113	456	.388	6.3
1200	238	1042	.369	12.5	1200	89	389	.400	5.1
1100	213	1018	.382	11.6	1100	68	326	.419	4.1
1000	190	999	.401	10.9	1000	51	270	.446	3.3

NOTE: Prop demand data is a cubic prop demand curve with 3.0 exponent for displacement hulls only.

RATING DEFINITIONS AND CONDITIONS

B Rating (Heavy Duty) –

% Load Factor: 40 to 80
% Time at Rated RPM: up to 40
Typical Time at Full Load: 10 hours out of 12
Typical Hour/Year: 3000 to 5000
Typical Applications: For vessels operating at rated load and rated speed up to 80% of the time with some load cycling (40% to 80% load factor). Typical applications could include but are not limited to vessels such as mid-water trawlers, purse seiner, crew and supply boats, ferries, or towboats. Typical operation ranges from 3000 to 5000 hours per year.

Power

at declared engine speed is in accordance with ISO3046-1:2002E. Caterpillar maintains ISO9001:1994/QS-9000 approved engine test facilities to assure calibration of test equipment. Electronically controlled engines are set at the factory at the advertised power corrected to standard ambient conditions. The published fuel consumption rates are in accordance with ISO3046-1:2002E.

Fuel rates

are based on fuel oil of 35° API [16°C (60°F)] gravity having an LHV of 42 780 kJ/kg (18,390 Btu/lb) when used at 29°C (85°F) and weighing 838.9 g/L (7.001 lb/U.S. gal). Additional ratings may be available for specific customer requirements. Consult your Caterpillar representative for additional information.

Performance data is calculated in accordance with tolerances and conditions stated in this specification sheet and is only intended for purposes of comparison with other manufacturer's engines. Actual engine performance may vary according to the particular application of the engine and operating conditions beyond Caterpillar's control.

Power produced at the flywheel will be within standard tolerances up to 49° C (120° F) combustion air temperature measured at the air cleaner inlet, and fuel temperature up to 52° C (125°F) measured at the fuel filter base. Power rated in accordance with NMMA procedure as crankshaft power. Reduce crankshaft power by 3% for propeller shaft power.

DIMENSIONS

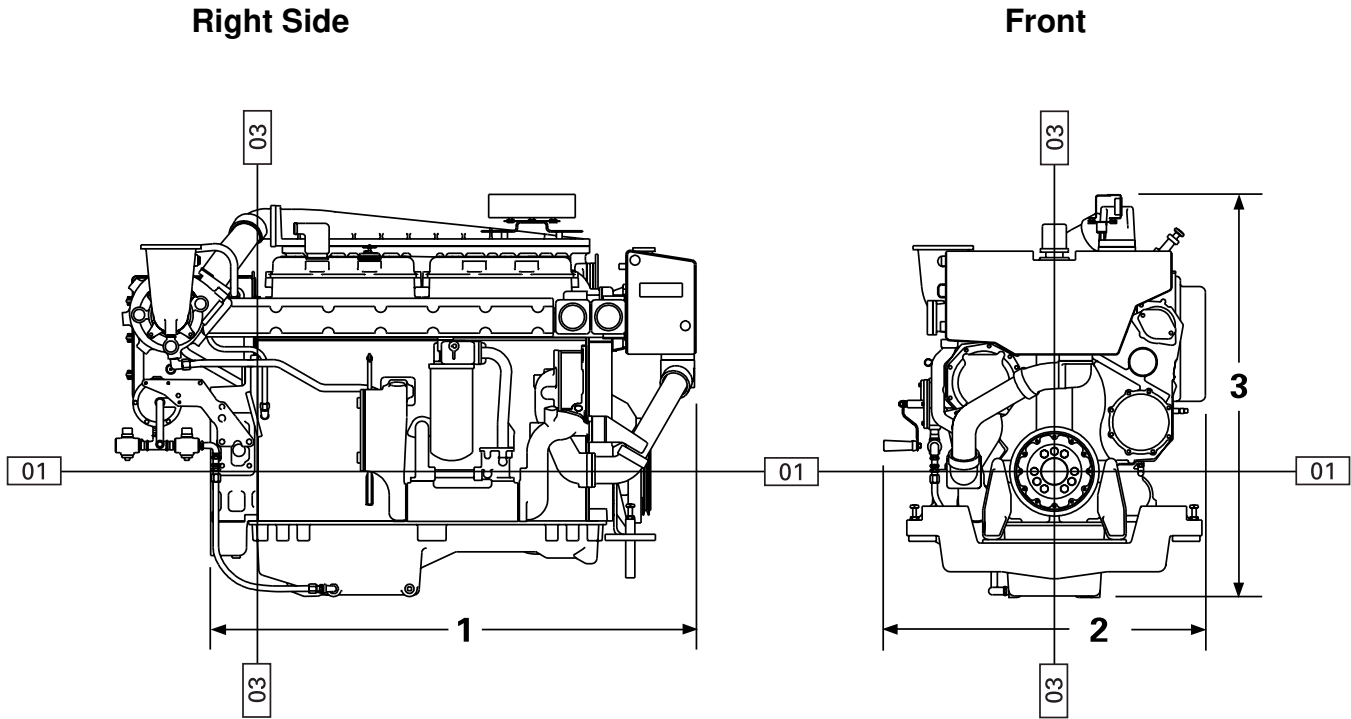

Engine Dimensions		
(1) Length to Flywheel Housing	1590.4 mm	62.61 in
(2) Width	1092.1 mm	43 in
(3) Height	1315.4 mm	51.79 in
Weight, Net Dry (approx)	1402 kg	3,091 lb

Note: Do not use for installation design. See general dimension drawings for detail (Drawing # 1806365).

Performance No.: DM6094-01

Feature Code: 406DM22

U.S. Sourced

7992983

29 September 2006

©2006 Caterpillar

All rights reserved.

Materials and specifications are subject to change without notice.

The International System of Units (SI) is used in this publication.

CAT, CATERPILLAR, their respective logos, "Caterpillar Yellow," and the POWER EDGE™ trade dress, as well as corporate and product identity used herein, are trademarks of Caterpillar and may not be used without permission.