

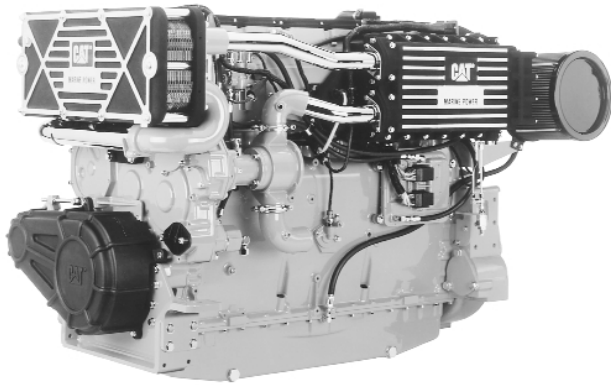

Marine Propulsion Engine 3406E

448 kW (600 bhp) 608 mhp @ 2100 rpm



Shown with Accessory Equipment

SPECIFICATIONS

I-6, 4-Stroke-Cycle-Diesel

Emissions	IMO compliant
Displacement	14.6 L (893 cu. in.)
Bore	137.2 mm (5.4 in.)
Stroke	165.1 mm (6.5 in.)
Aspiration	Turbocharged-Aftercooled
Governor	Electronic
Engine Weight, Net Dry (approx)	1586 kg (3497 lb)
Capacity for Liquids	
Cooling System	43.7 L (11.4 U.S. gal)
Lube Oil System (refill)	49 L (13 U.S. gal)
Oil Change Interval	250 hr
Caterpillar DEO 10W30 or 15W40	
Rotation (from flywheel end)	Counterclockwise

STANDARD EQUIPMENT

Air Inlet System

Corrosion resistant sea water aftercooler; light-duty air cleaner, open system

Cooling System

Self-priming sea water pump with rubber impeller, gear driven jacket water pump, titanium plate heat exchanger with expansion tank, coolant recovery system, thermostat and housing

Exhaust System

Watercooled manifold and turbocharger; round flanged outlet, 152 mm (6 in.)

Flywheel and Flywheel Housing

SAE No. 1 (113 teeth)

Fuel System

Fuel priming pump; fuel transfer pump; fuel filter — RH service on port, LH service on starboard; flexible fuel lines

Instruments

24-volt instrument panel with start/stop switch, emergency stop button, maintenance light, diagnostic light, warning light, 15-amp and 3-amp breakers, starter motor magnetic switch, electric service meter

Lube System

Crankcase breather; engine oil cooler; oil level gauge and oil filter — RH service on port, LH service on starboard; shallow oil pan; gear driven oil pump

Mounting System

Adjustable front support

General

Vibration damper and guard, Caterpillar yellow paint, lifting eyes

ACCESSORY EQUIPMENT

- Aftercooler Condensate Drain
- Air Starting Motor
- 12V 51 Amp, 12V 105 Amp Alternator
- Cruise Kits
- 12V/24V DC Converter
- Digital Tachometer
- Double Wall Fuel Lines and Drain
- Dress-Up Kit
- Duplex Fuel Filters
- Electric Starting Motor
- Engine Monitoring System
- Engine-to-Engine Wiring Harness
- Engine Vision Display System
- Exhaust Elbow, Dry or Watercooled
- Exhaust Pipe, Flange, Flexible Fittings
- Front Enclosed Clutch
- Front Stub Shaft
- Fuel Cooler
- GPS Interface Module
- Heavy-Duty Front Support
- Hydraulic Pump Drive
- 12V Instrument Panel
- Jacket Water Heater
- Marine Power Display
- OEM Wiring Harness
- Primary Fuel Filter/Water Separator
- Pulley and Damper
- Spare Parts Kit
- Throttle Position Sensor
- Transmission Oil Cooler
- Vibration Isolation Mounting

PERFORMANCE CURVES

C Rating — DM6120-00

IMO Compliant

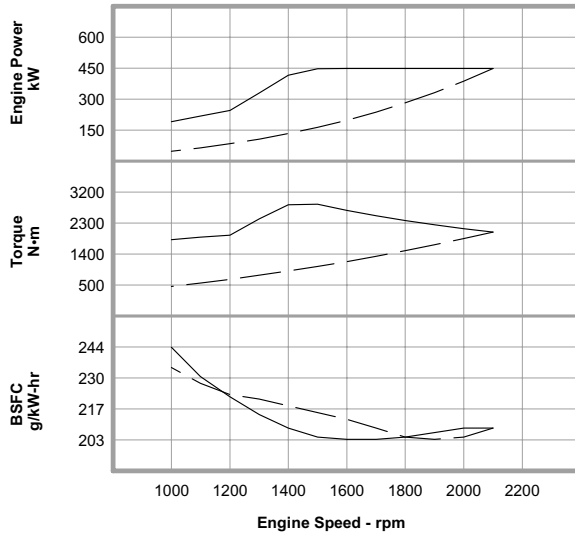

Metric **Maximum Power** ——— **448 kW**
Prop Demand - - - - -

Performance Data

	Engine Speed rpm	Engine Power kW	Engine Torque N·m	BSFC g/kW·hr	Fuel Rate L/hr
Maximum Power Data	2100	448	2035	208.0	111.1
	2000	448	2136	208.0	110.9
	1900	448	2249	206.0	109.8
	1800	448	2374	204.0	108.6
	1700	448	2513	203.0	108.3
	1600	448	2671	203.0	108.3
	1500	447	2848	204.0	108.7
	1400	415	2832	208.0	103.0
	1300	330	2425	214.0	84.3
	1200	245	1951	222.0	64.7
	1100	218	1894	231.0	60.1
1000	190	1815	244.0	55.3	
Prop Demand Data	2100	448	2035	208.0	111.1
	2000	387	1846	204.0	94.1
	1900	331	1666	203.0	80.1
	1800	282	1495	204.0	68.6
	1700	237	1333	208.0	58.7
	1600	198	1181	212.0	49.9
	1500	163	1038	215.0	41.9
	1400	133	904	218.0	34.5
	1300	106	780	221.0	27.9
	1200	84	664	223.0	22.2
	1100	64	558	228.0	17.5
1000	48	461	235.0	13.5	

Cubic prop demand curve with 3.0 exponent for displacement hulls only.

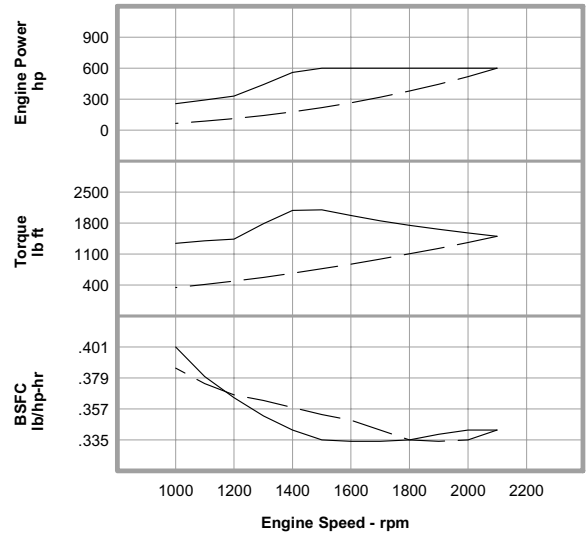

English **Maximum Power** ——— **600 hp**
Prop Demand - - - - -

Performance Data

	Engine Speed rpm	Engine Power hp	Engine Torque lb ft	BSFC lb/hp·hr	Fuel Rate gph
Maximum Power Data	2100	600	1501	.342	29.3
	2000	600	1575	.342	29.3
	1900	600	1659	.339	29.0
	1800	600	1751	.335	28.7
	1700	600	1853	.334	28.6
	1600	600	1970	.334	28.6
	1500	600	2100	.335	28.7
	1400	557	2089	.342	27.2
	1300	443	1788	.352	22.3
	1200	329	1439	.365	17.1
	1100	292	1397	.380	15.9
1000	255	1339	.401	14.6	
Prop Demand Data	2100	600	1501	.342	29.3
	2000	518	1361	.335	24.9
	1900	444	1229	.334	21.2
	1800	378	1103	.335	18.1
	1700	318	983	.342	15.5
	1600	265	871	.349	13.2
	1500	219	766	.353	11.1
	1400	178	667	.358	9.1
	1300	142	575	.363	7.4
	1200	112	490	.367	5.9
	1100	86	412	.375	4.6
1000	65	340	.386	3.6	

Power produced at the flywheel will be within standard tolerances up to 50°C (122°F) combustion air temperature measured at the air cleaner inlet, and fuel temperature up to 52°C (125°F) measured at the fuel filter base. Power rated in accordance with NMMA procedure as crankshaft power. Reduce crankshaft power by 3% for propeller shaft power.

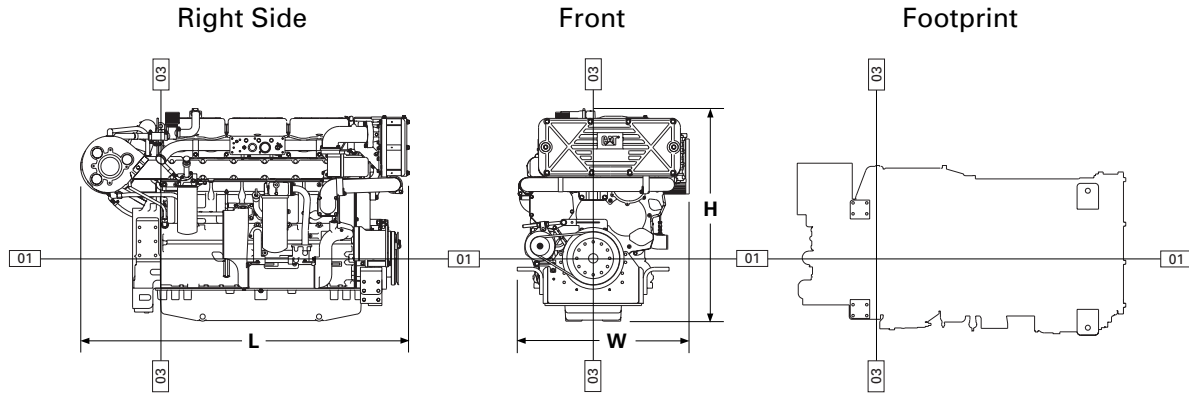

DIMENSIONS*

	mm	in.		
Overall Length	1822.7	71.8		
Length from front to rear face of block	1379.4	54.3		
Length from rear face of block to back of flywheel housing	155.1	6.1		
Overall Height	1177.8	46.4		
Height from crankshaft centerline to top of engine	829.8	32.7		
Height from crankshaft centerline to bottom of oil pan	348.0	13.7		
Overall Width	953.6	37.5		
Width from crankshaft centerline to port side (left side)	520.1	20.5		
Width from crankshaft centerline to starboard side (right side)	421.0	16.6		
	Front	in.	Rear	in.
Customer mounting hole diameter	27.5	1.1		5/8
Width from crankshaft centerline to mounting holes	380.0	15.0	252.4	9.9
			312.8	12.3
Length from rear face of block to mounting holes	1168.5	46.0	57.9	2.3
			134.1	5.3

*Illustrations and dimensions from drawing: 137-6875 Heat Exchanger Cooled.

RATING DEFINITIONS AND CONDITIONS

C Rating –

Typical Application . . . Vessels such as ferries, harbor tugs, fishing boats moving at higher speeds out and back (e.g. lobster, crayfish, and tuna), offshore service boats, and also displacement hull yachts and short trip coastal freighters where engine load and speed are cyclical.

Typical Hours Per Year	2000 to 4000
Time at Rated Speed	Up to 50%
Load Factor	20 to 80%
Typical Time at Full Load	6 out of 12 hours
Rated Speed	2100 rpm
Maximum Cruise Speed	2000 rpm
Maximum Continuous Cruise Speed	1900 rpm

Engine Performance Parameters

Power	±3%
Specific Fuel Consumption	±3%
Fuel Rate	±5%

Ratings are based on SAE J1228/ISO8665 standard conditions of 100 kPa (29.61 in. Hg), 25°C (77°F), and 30% relative humidity. These ratings also apply at ISO3046/1, DIN6271/3, and BS5514 conditions of 100 kPa (29.61 in. Hg), 27°C (81°F), and 60% relative humidity.

Fuel rates are based on fuel oil of 35° API [16°C (60°F)] gravity having an LHV of 42 780 kJ/kg (18,390 Btu/lb) when used at 29°C (85°F) and weighing 838.9 g/L (7.001 lb/U.S. gal).

Additional ratings may be available for specific customer requirements. Consult your Caterpillar representative for additional information.



3406E MARINE PROPULSION — 448 bkW (600 bhp)

Performance data is calculated in accordance with tolerances and conditions stated in this specification sheet and is only intended for purposes of comparison with other manufacturers' engines. Actual engine performance may vary according to the particular application of the engine and operating conditions beyond Caterpillar's control.

TMI Reference No.: DM6120-00 (6-19-01)

Materials and specifications are subject to change without notice.

The International System of Units (SI) is used in this publication.

LEHM1075-00 (6-01)

Supersedes LEHM8507-01

Printed in U.S.A.

©2001 Caterpillar
All rights reserved.