

Image may not reflect actual engine

CATERPILLAR® ENGINE SPECIFICATIONS

V-12, 4-Stroke-Cycle-Diesel

Emissions IMO compliant
 Displacement 27 L (1649 cu. in.)
 Bore 137 mm (5.4 in.)
 Stroke 152 mm (6.0 in.)
 Aspiration Turbocharged-Aftercooled
 Governor Hydra-mechanical or PSG
 Engine Weight, Net Dry (approx) 4327 kg (9540 lb)
 Capacity for Liquids
 Cooling System (engine only) 61 L (16.3 U.S. gal)
 Lube Oil System (refill) 136.3 L (36 U.S. gal)
 Oil Change Interval 500 hr
 Caterpillar DEO 10W30 or 15W40
 Rotation (from flywheel end) Counterclockwise

STANDARD EQUIPMENT

Air Inlet System

Corrosion resistant aftercooler core; regular duty panel-type air cleaner

Cooling System

Gear driven, centrifugal auxiliary sea water pump; gear driven, centrifugal jacket water pump; oil cooler; expansion tank; thermostats and housing with 92°C (198°F) full open temperature

Exhaust System

Watercooled manifold and turbocharger; dry elbow and flange, 203 mm (8 in.)

Flywheel and Flywheel Housing

SAE No. 0 (136 teeth)

Fuel System

Fuel priming pump, fuel transfer pump, RH fuel filter, flexible fuel lines

Generator and Attachments

Brushless PM excited SR4 generator, VR3 voltage regulator, space heater

Instruments

RH instrument panel with oil pressure, water temperature, and fuel pressure gauges

Lube System

RH oil level gauge and oil filter, crankcase breather, oil filler in valve cover, deep sump oil pan

Mounting System

Rails, 85 mm (3.3 in.) height

General

Vibration damper, Caterpillar yellow paint, lifting eyes

ACCESSORY EQUIPMENT

Air starting motor
 24V 35 amp, 24V 60 amp alternator
 Alarm contactor — oil pressure, water temperature
 Auxiliary sea water pump
 Digital tachometer
 Double wall fuel lines and drain
 Dry change coolant conditioner
 Duplex fuel filters
 Duplex oil filters
 24V or 32V electric gauges
 24V electrical shutoffs — oil pressure, water temperature
 Extension terminal box
 Exhaust elbow, pipe, flange, flexible fittings
 Heat exchanger
 4- or 8-hole instrument panel
 LH oil level gauge
 Low voltage connections
 Magnetic pickup
 Manual voltage control
 Mechanical shutoffs — oil pressure, water temperature
 Mechanical tachometer drive
 Primary fuel filter/water separator
 RFI filter
 Solenoid shutoff — 24V ETR, ETS
 Spare parts kit

PERFORMANCE DATA

Turbocharged-Aftercooled

DM6088-00

500 ekW (.8 pf) 625 kVA			
% load	ekW	Lph	gph
100	500	141.3	37.3
75	375	104.8	27.7
50	250	73.9	19.5
25	125	44.4	11.7

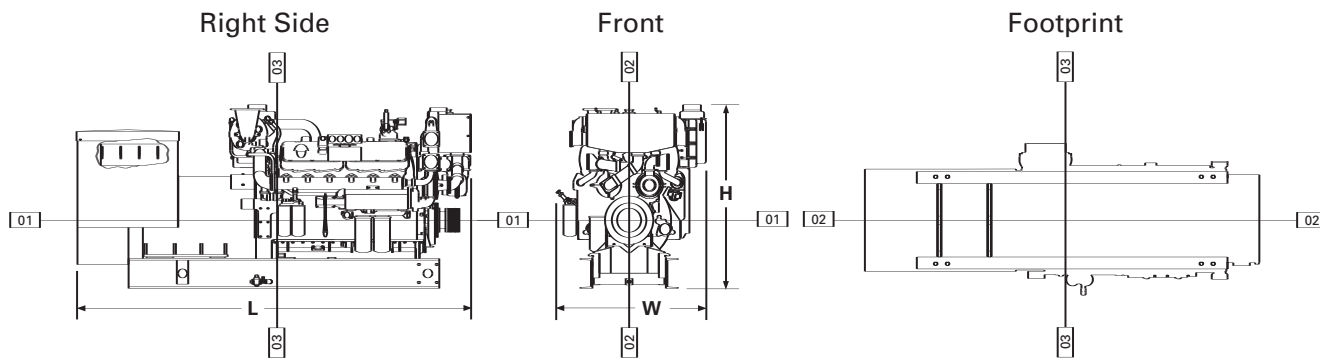

DIMENSIONS*

	mm	in.
Overall Length	3476.5	136.9
Length from front to rear face of block	1643.2	64.7
Length from rear face of block to back of generator	1833.3	72.2
Overall Height	1555.7	61.3
Height from crankshaft centerline to top of engine	977.9	38.5
Height from crankshaft centerline to bottom of rails	577.8	22.8
Overall Width	1266.7	49.9
Width from crankshaft centerline to port side (left side)	650.7	25.6
Width from crankshaft centerline to starboard side (right side)	616.0	24.3

	Front		Rear	
	mm	in.	mm	in.
Customer mounting hole diameter	30.5	1.2	30.5	1.2
Width from crankshaft centerline to mounting holes	368.3	14.5	368.3	14.5
Length from rear face of block to mounting holes	1151.3	45.3	998.7	39.3
	1251.3	49.3	1098.7	43.3

*Illustrations and dimensions from drawing: 154-0920.

CATERPILLAR SR4 GENERATOR

Type Brushless, revolving field, solid state self-excited
 Construction Single bearing, close coupled
 Three-phase 10 wire, wye connected
 Insulation Class F with tropicalization and anti-abrasion
 Alignment Pilot shaft
 Voltage Regulator Generator mounted, volts-per-hertz
 Voltage Droop Adjustable for parallel operation
 Voltage Regulation ±1/2%
 Voltage Gain Adjustable
 Generator Weight, Net (approx)
 594 frame 1714 kg (3779 lb)
 Space Heater
 Voltages Available (adjustable +10%, -5%)
 60 Hz — 220-440 volts
 Meets or exceeds Marine Society requirements

RATING CONDITIONS

Engine Performance Parameters
 Power ±3%
 Specific Fuel Consumption ±3%
 Fuel Rate ±5%

Ratings are based on SAE J1228/ISO8665 standard conditions of 100 kPa (29.61 in. Hg), 25°C (77°F), and 30% relative humidity. These ratings also apply at ISO3046/1, DIN6271/3, and BS5514 conditions of 100 kPa (29.61 in. Hg), 27°C (81°F), and 60% relative humidity.

Fuel rates are based on fuel oil of 35° API [16°C (60°F)] gravity having an LHV of 42 780 kJ/kg (18,390 Btu/lb) when used at 29°C (85°F) and weighing 838.9 g/L (7.001 lb/U.S. gal).

Additional ratings may be available for specific customer requirements. Consult your Caterpillar representative for additional information.

Performance data is calculated in accordance with tolerances and conditions stated in this specification sheet and is only intended for purposes of comparison with other manufacturers' engines. Actual engine performance may vary according to the particular application of the engine and operating conditions beyond Caterpillar's control.

CAT, CATERPILLAR, their respective logos, "Caterpillar Yellow" and the POWER EDGE trade dress, as well as corporate and product identity used herein, are trademarks of Caterpillar and may not be used without permission.