

Image may not reflect actual engine

## CATERPILLAR® ENGINE SPECIFICATIONS

### V-12, 4-Stroke-Cycle-Diesel

Emissions . . . . . IMO compliant  
 Displacement . . . . . 27 L (1649 cu. in.)  
 Bore . . . . . 137 mm (5.4 in.)  
 Stroke . . . . . 152 mm (6.0 in.)  
 Aspiration . . . . . Turbocharged-Aftercooled  
 Governor . . . . . PSG  
 Engine Weight, Net Dry (approx) . . . . . 4327 kg (9540 lb)  
 Capacity for Liquids  
     Cooling System (engine only) . . . . . 61 L (16.1 U.S. gal)  
     Lube Oil System (refill) . . . . . 136.3 L (36 U.S. gal)  
 Oil Change Interval . . . . . 500 hr  
     Caterpillar DEO 10W30 or 15W40  
 Rotation (from flywheel end) . . . . . Counterclockwise

## STANDARD EQUIPMENT

### Air Inlet System

Corrosion resistant aftercooler core; regular duty panel-type air cleaner

### Alarm and Protection System

Magnetic pickup, remote alarm and protection panel, sensors wired to package-mounted junction box

### Cooling System

Gear driven, centrifugal auxiliary sea water pump; gear driven, centrifugal jacket water pump; oil cooler; expansion tank; thermostats and housing with 92°C (198°F) full open temperature

### Exhaust System

Watercooled manifold and turbocharger; dry elbow and flange, 203 mm (8 in.)

### Flywheel and Flywheel Housing

SAE No. 0 (136 teeth)

### Fuel System

Fuel priming pump, fuel transfer pump, RH duplex fuel filter, minimized flexible fuel lines, double wall fuel lines and drain

### Generator and Attachments

Brushless PM excited SR4 generator, VR3 voltage regulator, space heater

### Instruments

RH instrument panel with oil pressure, water temperature, and fuel pressure gauges

### Lube System

RH oil level gauge and oil filter, crankcase breather, oil filler in valve cover, deep sump oil pan

### Mounting System

Rails, 85 mm (3.3 in.) height

### General

Vibration damper, Caterpillar yellow paint, lifting eyes

## ACCESSORY EQUIPMENT

Air starting motor  
 24V 35 amp, 24V 60 amp alternator  
 Auxiliary sea water pump  
 Dry change coolant conditioner  
 Duplex oil filters  
 Extension terminal box  
 Exhaust elbow, pipe, flange, flexible fittings  
 Heat exchanger  
 LH oil level gauge  
 Low voltage connections  
 Manual voltage control  
 Primary fuel filter/water separator  
 RFI filter  
 Solenoid shutoff — 24V ETR, ETS  
 Spare parts kit

## PERFORMANCE DATA

Turbocharged-Aftercooled

DM6085-00

405 ekW (.8 pf) 506 kVA			
% load	ekW	Lph	gph
100	405	113.1	29.9
75	304	84.2	22.2
50	203	58.3	15.4
25	101	34.2	9.0

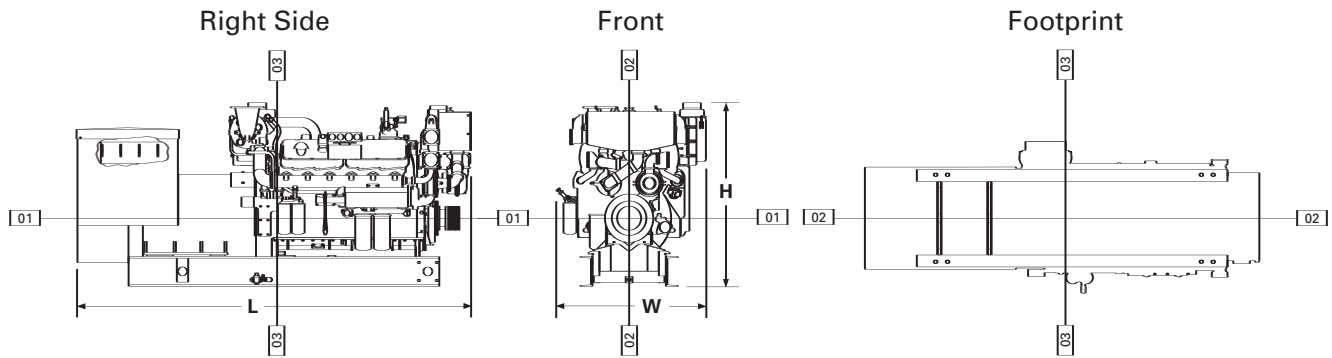

### DIMENSIONS

	mm	in.
<b>Overall Length</b>	3476.5	136.9
Length from front to rear face of block	1643.2	64.7
Length from rear face of block to back of generator	1833.3	72.2
<b>Overall Height</b>	1555.7	61.3
Height from crankshaft centerline to top of engine	977.9	38.5
Height from crankshaft centerline to bottom of rails	577.8	22.8
<b>Overall Width</b>	1266.7	49.9
Width from crankshaft centerline to port side (left side)	650.7	25.6
Width from crankshaft centerline to starboard side (right side)	616.0	24.3

	Front		Rear	
	mm	in.	mm	in.
Customer mounting hole diameter	30.5	1.2	30.5	1.2
Width from crankshaft centerline to mounting holes	368.3	14.5	368.3	14.5
Length from rear face of block to mounting holes	1151.3	45.3	998.7	39.3
	1251.3	49.3	1098.7	43.3

### CATERPILLAR SR4 GENERATOR

- Type . . . . . Brushless, revolving field, solid state self-excited
- Construction . . . . . Single bearing, close coupled
- Three-phase . . . . . 10 wire, wye connected
- Insulation . . . . . Class F with tropicalization and anti-abrasion
- Alignment . . . . . Pilot shaft
- Voltage Regulator . . . . . Generator mounted, volts-per-hertz
- Voltage Droop . . . . . Adjustable for parallel operation
- Voltage Regulation . . . . . ±1/2%
- Voltage Gain . . . . . Adjustable
- Generator Weight, Net (approx)  
594 frame . . . . . 1714 kg (3779 lb)
- Space Heater
- Voltages Available (adjustable +10%, -5%)  
50 Hz — 190-380 volts
- Meets or exceeds Marine Society requirements

### RATING CONDITIONS

- Engine Performance Parameters**
- Power . . . . . ±3%
  - Specific Fuel Consumption . . . . . ±3%
  - Fuel Rate . . . . . ±5%

**Ratings** are based on SAE J1228/ISO8665 standard conditions of 100 kPa (29.61 in. Hg), 25°C (77°F), and 30% relative humidity. These ratings also apply at ISO3046/1, DIN6271/3, and BS5514 conditions of 100 kPa (29.61 in. Hg), 27°C (81°F), and 60% relative humidity.

**Fuel rates** are based on fuel oil of 35° API [16°C (60°F)] gravity having an LHV of 42 780 kJ/kg (18,390 Btu/lb) when used at 29°C (85°F) and weighing 838.9 g/L (7.001 lb/U.S. gal).

Additional ratings may be available for specific customer requirements. Consult your Caterpillar representative for additional information.

Performance data is calculated in accordance with tolerances and conditions stated in this specification sheet and is only intended for purposes of comparison with other manufacturers' engines. Actual engine performance may vary according to the particular application of the engine and operating conditions beyond Caterpillar's control.

CAT, CATERPILLAR, their respective logos, "Caterpillar Yellow" and the POWER EDGE trade dress, as well as corporate and product identity used herein, are trademarks of Caterpillar and may not be used without permission.