



# Marine Generator Set 3412C

590 kW (738 kVA) 60 Hz @ 1800 rpm



Shown with Accessory Equipment

## CATERPILLAR ENGINE SPECIFICATIONS

### V-12, 4-Stroke-Cycle-Diesel

- Emissions . . . . . IMO compliant
- Displacement . . . . . 27 L (1649 cu. in.)
- Bore . . . . . 137 mm (5.4 in.)
- Stroke . . . . . 152 mm (6.0 in.)
- Aspiration . . . . . Turbocharged-Aftercooled
- Governor . . . . . Hydra-mechanical or PSG
- Engine Weight, Net Dry (approx) . . . . . 4327 kg (9540 lb)
- Capacity for Liquids
  - Cooling System (engine only) . . . . . 61 L (16.3 U.S. gal)
  - Lube Oil System (refill) . . . . . 136.3 L (36 U.S. gal)
- Oil Change Interval . . . . . 500 hr  
Caterpillar DEO 10W30 or 15W40
- Rotation (from flywheel end) . . . . . Counterclockwise

## STANDARD EQUIPMENT

### Air Inlet System

Corrosion resistant aftercooler core; regular duty panel-type air cleaner

### Cooling System

Gear driven, centrifugal auxiliary sea water pump; gear driven, centrifugal jacket water pump; oil cooler; expansion tank; thermostats and housing with 92°C (198°F) full open temperature

### Exhaust System

Watercooled manifold and turbocharger; dry elbow and flange, 203 mm (8 in.)

### Flywheel and Flywheel Housing

SAE No. 0 (136 teeth)

### Fuel System

Fuel priming pump, fuel transfer pump, RH fuel filter, flexible fuel lines

### Generator and Attachments

Brushless PM excited SR4 generator, VR3 voltage regulator, space heater

### Instruments

RH instrument panel with oil pressure, water temperature, and fuel pressure gauges

### Lube System

RH oil level gauge and oil filter, crankcase breather, oil filler in valve cover, deep sump oil pan

### Mounting System

Rails, 85 mm (3.3 in.) height

### General

Vibration damper, Caterpillar yellow paint, lifting eyes

## ACCESSORY EQUIPMENT

- Air Starting Motor
- 24V 35 Amp, 24V 60 Amp Alternator
- Alarm Contactor — Oil Pressure, Water Temperature
- Auxiliary Sea Water Pump
- Digital Tachometer
- Double Wall Fuel Lines and Drain
- Dry Change Coolant Conditioner
- Duplex Fuel Filters
- Duplex Oil Filters
- 24V or 32V Electric Gauges
- 24V Electrical Shutoffs — Oil Pressure, Water Temperature
- Extension Terminal Box
- Exhaust Elbow, Pipe, Flange, Flexible Fittings
- Heat Exchanger
- 4- or 8-Hole Instrument Panel
- LH Oil Level Gauge
- Low Voltage Connections
- Magnetic Pickup
- Manual Voltage Control
- Mechanical Shutoffs — Oil Pressure, Water Temperature
- Mechanical Tachometer Drive
- Primary Fuel Filter/Water Separator
- RFI Filter
- Solenoid Shutoff — 24V ETR, ETS
- Spare Parts Kit

## PERFORMANCE DATA

Turbocharged-Aftercooled

DM6089-00

590 kW (.8 pf) 738 kVA			
% load	ekW	Lph	gph
100	590	166.1	43.9
75	443	122.4	32.3
50	295	84.9	22.4
25	148	50.0	13.2

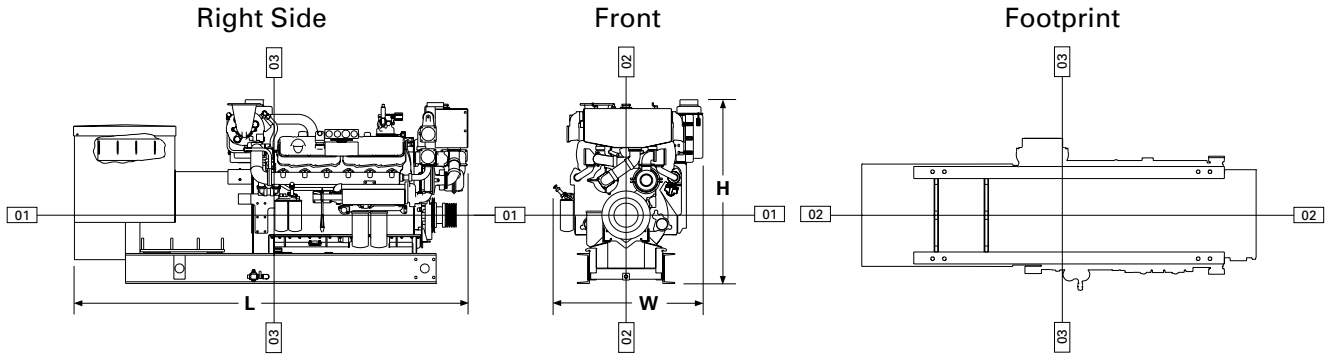

**DIMENSIONS\***

	mm	in.		
<b>Overall Length</b>	3476.5	136.9		
Length from front to rear face of block	1643.2	64.7		
Length from rear face of block to back of generator	1833.3	72.2		
<b>Overall Height</b>	1555.7	61.3		
Height from crankshaft centerline to top of engine	977.9	38.5		
Height from crankshaft centerline to bottom of rails	577.8	22.8		
<b>Overall Width</b>	1266.7	49.9		
Width from crankshaft centerline to port side (left side)	650.7	25.6		
Width from crankshaft centerline to starboard side (right side)	616.0	24.3		
			<b>Front</b>	<b>Rear</b>
	<b>mm</b>	<b>in.</b>	<b>mm</b>	<b>in.</b>
Customer mounting hole diameter	30.5	1.2	30.5	1.2
Width from crankshaft centerline to mounting holes	368.3	14.5	368.3	14.5
Length from rear face of block to mounting holes	1151.3	45.3	998.7	39.3
	1251.3	49.3	1098.7	43.3

\*Illustrations and dimensions from drawing: 154-0920.

**CATERPILLAR SR4 GENERATOR**

- Type . . . . . Brushless, revolving field, solid state self-excited
- Construction . . . . . Single bearing, close coupled
- Three-phase . . . . . 10 wire, wye connected
- Insulation . . . . . Class F with tropicalization and anti-abrasion
- Alignment . . . . . Pilot shaft
- Voltage Regulator . . . . . Generator mounted, volts-per-hertz
- Voltage Droop . . . . . Adjustable for parallel operation
- Voltage Regulation . . . . . ±1/2%
- Voltage Gain . . . . . Adjustable
- Generator Weight, Net (approx)  
596 frame . . . . . 2129 kg (4693 lb)
- Space Heater
- Voltages Available (adjustable +10%, -5%)  
60 Hz — 220-440 volts
- Meets or exceeds Marine Society requirements

**RATING CONDITIONS**

- Engine Performance Parameters**
- Power . . . . . ±3%
  - Specific Fuel Consumption . . . . . ±3%
  - Fuel Rate . . . . . ±5%
- Ratings** are based on SAE J1228/ISO8665 standard conditions of 100 kPa (29.61 in. Hg), 25°C (77°F), and 30% relative humidity. These ratings also apply at ISO3046/1, DIN6271/3, and BS5514 conditions of 100 kPa (29.61 in. Hg), 27°C (81°F), and 60% relative humidity.
- Fuel rates** are based on fuel oil of 35° API [16°C (60°F)] gravity having an LHV of 42 780 kJ/kg (18,390 Btu/lb) when used at 29°C (85°F) and weighing 838.9 g/L (7.001 lb/U.S. gal).
- Additional ratings may be available for specific customer requirements. Consult your Caterpillar representative for additional information.

Performance data is calculated in accordance with tolerances and conditions stated in this specification sheet and is only intended for purposes of comparison with other manufacturers' engines. Actual engine performance may vary according to the particular application of the engine and operating conditions beyond Caterpillar's control.