

Cat® D600 GC DIESEL GENERATOR SETS



Standby: 60 Hz, 480V & 600V



Image shown might not reflect actual configuration

Engine Model	Cat® C18 In-line 6, 4-cycle diesel
Bore x Stroke	145mm x 183mm (5.7in x 7.2in)
Displacement	18.1 L (1106 in ³)
Compression Ratio	14.5:1
Aspiration	Turbocharged Air-to-Air Aftercooled
Fuel Injection System	MEUI
Governor	Electronic ADEM™ A4

Standby	Performance Strategy
600 ekW, 750 kVA	EPA Certified for Stationary Emergency Application

PACKAGE PERFORMANCE

Performance	Standby	
Frequency	60 Hz	
Genset Power Rating	750 kVA	
Gen set power rating with fan @ 0.8 power factor	600 ekW	
Emissions	EPA TIER 2	
Performance Number	DM8518	
Fuel Consumption		
100% load with fan	161.1 L/hr	35.4 gal/hr
75% load with fan	129.6 L/hr	28.5 gal/hr
50% load with fan	91.7 L/hr	20.2 gal/hr
25% load with fan	46.8 L/hr	12.3 gal/hr
Cooling System ¹		
Radiator air flow restriction (system)	0.12 kPa	0.48 in. Water
Radiator air flow	803 m ³ /min	28357 cfm
Engine coolant capacity	20.8 L	5.5 gal
Radiator coolant capacity	61 L	16 gal
Total coolant capacity	82 L	22 gal
Inlet Air		
Combustion air inlet flow rate	47.8 m ³ /min	994.3 cfm
Max. Allowable Combustion Air Inlet Temp	49°C	122°F
Exhaust System		
Exhaust stack gas temperature	534.6°C	994.3°F
Exhaust gas flow rate	135.5 m ³ /min	4784.4 cfm
Exhaust system backpressure (maximum allowable)	10.0 kPa	40.0 in. water
Heat Rejection		
Heat rejection to jacket water	180 kW	10236 Btu/min
Heat rejection to exhaust (total)	595 kW	33837 Btu/min
Heat rejection to aftercooler	141 kW	8019 Btu/min
Heat rejection to atmosphere from engine	77 kW	4379 Btu/min
Heat rejection from alternator	33 kW	1854 Btu/min

Emissions (Nominal) ²	Standby	
NO _x	2703.5 mg/Nm ³	5.5 g/hp-hr
CO	161.0 mg/Nm ³	0.3 g/hp-hr
HC	4.6 mg/Nm ³	0.01 g/hp-hr
PM	13.2 mg/Nm ³	0.03 g/hp-hr
Alternator ³		
Voltages	480V	600V
Motor Starting Capability @ 30% Voltage Dip	1199	1292
Current	902.1	721.7
Frame Size	M3154L4	M3156L4
Excitation	S.E	AREP
Temperature Rise	105°C	130°C

WEIGHTS & DIMENSIONS – OPEN SET

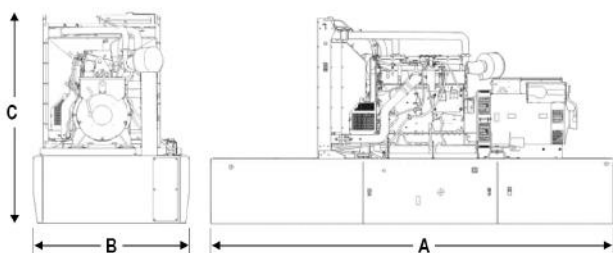

Base	Dim "A" mm (in)	Dim "B" mm (in)	Dim "C" mm (in)	Generator Set Weight kg (lb)
Skid (Wide Base)	4980 (196.1)	1865 (73.4)	2009 (79.1)	4064 (8959.6)
Integral Tank Base	4980 (196.1)	1865 (73.4)	2563 (100.9)	5283 (11647.0)

FUEL TANK CAPACITY

Tank Design	Total Capacity		Useable Capacity	
	Litre	Gallon	Litre	Gallon
Integral	4292	1133.8	3889	1027.3

DEFINITIONS AND CONDITIONS

¹ For ambient and altitude capabilities consult your Cat dealer. Air flow restriction (system) is added to existing restriction from factory.

² Emissions data measurement procedures are consistent with those described in EPA CFR 40 Part 89, Subpart D & E and ISO 8178-1 for measuring HC, CO, PM, NO_x. Data shown is based on steady state operating conditions of 77° F, 28.42 in HG and number 2 diesel fuel with 35° API and LHV of 18,390 BTU/lb. The nominal emissions data shown is subject to instrumentation, measurement, facility and engine to engine variations. Emissions data is based on 100% load and thus cannot be used to compare to EPA regulations which use values based on a weighted cycle.

³ UL 2200 Listed packages may have oversized generators with a different temperature rise and motor starting characteristics. Generator temperature rise is based on a 40° C ambient per NEMA MG1-32.

APPLICABLE CODES AND STANDARDS:

AS1359, CSA C22.2 No100-04, UL142, UL489, UL869, UL2200, NFPA37, NFPA70, NFPA99, NFPA110, IBC, IEC60034-1, ISO3046, ISO8528, NEMA MG1-22, NEMA MG1-33, 2006/95/EC, 2006/42/EC, 2004/108/EC.

Note: Codes may not be available in all model configurations. Please consult your local Cat Dealer representative for availability.

STANDBY: Output available with varying load for the duration of the interruption of the normal source power. Average power output is 70% of the standby power rating. Typical operation is 200 hours per year, with maximum expected usage of 500 hours per year.

RATINGS: Ratings are based on SAE J1349 standard conditions. These ratings also apply at ISO3046 standard conditions.

Fuel Rates are based on fuel oil of 35° API [16° C (60° F)] gravity having an LHV of 42 780 kJ/kg (18,390 Btu/lb) when used at 29° C (85° F) and weighing 838.9 g/litre (7.001 lbs/U.S. gal.). Additional ratings may be available for specific customer requirements, contact your Caterpillar representative for details. For information regarding Low Sulfur fuel and Biodiesel capability, please consult your Cat dealer.

LEHE2013-07 (10-20)

www.Cat.com/electricpower

© 2020 Caterpillar. All rights reserved. Materials and specifications are subject to change without notice. The International System of Units (SI) is used in this publication. CAT, CATERPILLAR, their respective logos, "Caterpillar Corporate Yellow", the "Power Edge" and Cat "Modern Hex" trade dress as well as corporate and product identity used here in, are trademarks of Caterpillar and may not be used without permission.



Effective with sales to the first user on or after August 1, 2016

CATERPILLAR LIMITED WARRANTY

Industrial, Petroleum, Locomotive, and Agriculture Engine Products and Electric Power Generation Products

Worldwide

Caterpillar Inc. or any of its subsidiaries ("Caterpillar") warrants new and remanufactured engines and new and rebuild electric power generation products sold by it (including any products of other manufacturers packaged and sold by Caterpillar), to be free from defects in material and workmanship.

This warranty does not apply engines sold for use in on-highway vehicle or marine applications; engines in machines manufactured by or for Caterpillar; C175, 3500 and 3600 series engines used in locomotive applications; 3000 Family engines, C0.5 through C4.4 and ACERT™ (C6.6, C7, C7.1, C9, C9.3, C11, C13, C15, C18, C27, and C32) engines used in industrial, mobile agriculture and locomotive applications; or Cat[®] batteries; or Electric Power Generation Products manufactured or assembled in India. These products are covered by other Caterpillar warranties.

This warranty is subject to the following:

Warranty Period

- For industrial engines, engines in a petroleum applications or Petroleum Power Systems (excluding petroleum fire pump application), or engines in a Locomotive application, or Uninterruptible Power Supply (UPS) systems, the warranty period is 12 months after date of delivery to the first user.
- For engines used in petroleum fire pump and mobile agriculture applications the warranty period is 24 months after date of delivery to the first user.
- For controls only (EPIC), configurable and custom switchgear products, and automatic transfer switch products, the warranty period is 24 months after date of delivery to the first user.
- For new CG132, CG170 and CG260 series power generation products the warranty period is 24 months/16,000 hours, whichever comes first, after date of delivery to first user.
- For electric power generation products other than CG132, CG170 and CG260 series in prime or continuous applications the warranty period is 12 months. For standby applications the warranty period is 24 months/1000 hours. For emergency standby applications the warranty period is 24 months/400 hours. All terms begin after date of delivery to the first user.
- For Caterpillar rebuild electric power generation products the warranty period is 12 months, but not to exceed 24 months from shipment of rebuilt electric power generation product from Caterpillar.
- For all other applications the warranty period is 12 months after date of delivery to the first user.

Caterpillar Responsibilities

If a defect in material or workmanship is found during the warranty period, Caterpillar will, during normal working hours and at a place of business of a Cat dealer or other source approved by Caterpillar:

- Provide (at Caterpillar's choice) new, Remanufactured, or Caterpillar approved repaired parts or assembled components needed to correct the defect.
- **Note:** New, remanufactured, or Caterpillar approved repaired parts or assembled components provided under the terms of this warranty are warranted for the remainder of the warranty period applicable to the product in which installed as if such parts were original components of that product. Items replaced under this warranty become the property of Caterpillar.
- Replace lubricating oil, filters, coolant, and other service items made unusable by the defect.
- Provide reasonable and customary labor needed to correct the defect, including labor to disconnect the product from and reconnect the product to its attached equipment, mounting, and support systems, if required.

For new 3114, 3116, and 3126 engines and, new and Caterpillar rebuild electric power generation products (which includes the following: any new products of other manufacturers packaged and sold by Caterpillar)

- Provide travel labor, up to four hours round trip, if in the opinion of Caterpillar, the product cannot reasonably be transported to a place of business of a Cat dealer or other source approved by Caterpillar (travel labor in excess of four hours round trip, and any meals, mileage, lodging, etc. is the user's responsibility).

For all other products:

- Provide reasonable travel expenses for authorized mechanics, including meals, mileage, and lodging, when Caterpillar chooses to make the repair on-site.

User Responsibilities

The user is responsible for:

- Providing proof of the delivery date to the first user.
- Labor costs, except as stated under "Caterpillar Responsibilities," including costs beyond those required to disconnect the product from and reconnect the product to its attached equipment, mounting, and support systems.

- Travel or transporting costs, except as stated under "Caterpillar Responsibilities."
- Premium or overtime labor costs.
- Parts shipping charges in excess of those that are usual and customary.
- Local taxes, if applicable.
- Costs to investigate complaints, unless the problem is caused by a defect in Caterpillar material or workmanship.
- Giving timely notice of a warrantable failure and promptly making the product available for repair.
- Performance of the required maintenance (including use of proper fuel, oil, lubricants, and coolant) and items replaced due to normal wear and tear.
- Allowing Caterpillar access to all electronically stored data.

Limitations

Caterpillar is not responsible for:

- Failures resulting from any use or installation that Caterpillar judges improper.
- Failures resulting from attachments, accessory items, and parts not sold or approved by Caterpillar.
- Failures resulting from abuse, neglect, and/or improper repair.
- Failures resulting from user's delay in making the product available after being notified of a potential product problem.
- Failures resulting from unauthorized repairs or adjustments, and unauthorized fuel setting changes.
- Damage to parts, fixtures, housings, attachments, and accessory items that are not part of the engine, Cat Selective Catalytic Reduction System or electric power generation product (including any products of other manufacturers packaged and sold by Caterpillar).
- Repair of components sold by Caterpillar that is warranted directly to the user by their respective manufacturer. Depending on type of application, certain exclusions may apply. Consult your Cat dealer for more information.

(Continued on reverse side...)

This warranty covers every major component of the products. Claims under this warranty should be submitted to a place of business of a Cat dealer or other source approved by Caterpillar. For further information concerning either the location to submit claims or Caterpillar as the issuer of this warranty, write Caterpillar Inc., 100 N. E. Adams St., Peoria, IL USA 61629.

Caterpillar's obligations under this Limited Warranty are subject to, and shall not apply in contravention of, the laws, rules, regulations, directives, ordinances, orders, or statutes of the United States, or of any other applicable jurisdiction, without recourse or liability with respect to Caterpillar.

A) For products operating outside of Australia, Fiji, Nauru, New Caledonia, New Zealand, Papua New Guinea, the Solomon Islands and Tahiti, the following is applicable:

NEITHER THE FOREGOING EXPRESS WARRANTY NOR ANY OTHER WARRANTY BY CATERPILLAR, EXPRESS OR IMPLIED, IS APPLICABLE TO ANY ITEM CATERPILLAR SELLS THAT IS WARRANTED DIRECTLY TO THE USER BY ITS MANUFACTURER.

THIS WARRANTY IS EXPRESSLY IN LIEU OF ANY OTHER WARRANTIES, EXPRESS OR IMPLIED, INCLUDING ANY WARRANTY OF MERCHANTABILITY OR FITNESS FOR A PARTICULAR PURPOSE, EXCEPT CATERPILLAR EMISSION-RELATED COMPONENTS WARRANTIES FOR NEW ENGINES, WHERE APPLICABLE. REMEDIES UNDER THIS WARRANTY ARE LIMITED TO THE PROVISION OF MATERIAL AND SERVICES, AS SPECIFIED HEREIN.

CATERPILLAR IS NOT RESPONSIBLE FOR INCIDENTAL OR CONSEQUENTIAL DAMAGES.

CATERPILLAR EXCLUDES ALL LIABILITY FOR OR ARISING FROM ANY NEGLIGENCE ON ITS PART OR ON THE PART OF ANY OF ITS EMPLOYEES, AGENTS OR REPRESENTATIVES IN RESPECT OF THE MANUFACTURE OR SUPPLY OF GOODS OR THE PROVISION OF SERVICES RELATING TO THE GOODS.

IF OTHERWISE APPLICABLE, THE VIENNA CONVENTION ON CONTRACTS FOR THE INTERNATIONAL SALE OF GOODS IS EXCLUDED IN ITS ENTIRETY.

For personal or family use engines or electric power generation products, operating in the USA, its territories and possessions, some states do not allow limitations on how long an implied warranty may last nor allow the exclusion or limitation of incidental or consequential damages. Therefore, the previously expressed exclusion may not apply to you. This warranty gives you specific legal rights and you may also have other rights, which vary by jurisdiction. To find the location of the nearest Cat dealer or other authorized repair facility, call (800) 447-4986. If you have questions concerning this warranty or its applications, call or write:

In USA and Canada: Caterpillar Inc., Engine Division, P. O. Box 610, Mossville, IL 61552-0610, Attention: Customer Service Manager, Telephone (800) 447-4986. Outside the USA and Canada: Contact your Cat dealer.

B) For products operating in Australia, Fiji, Nauru, New Caledonia, New Zealand, Papua New Guinea, the Solomon Islands and Tahiti, the following is applicable:

THIS WARRANTY IS IN ADDITION TO WARRANTIES AND CONDITIONS IMPLIED BY STATUTE AND OTHER STATUTORY RIGHTS AND OBLIGATIONS THAT BY ANY APPLICABLE LAW CANNOT BE EXCLUDED, RESTRICTED OR MODIFIED ("MANDATORY RIGHTS"). ALL OTHER WARRANTIES OR CONDITIONS, EXPRESS OR IMPLIED (BY STATUTE OR OTHERWISE), ARE EXCLUDED. WITHOUT LIMITING THE FOREGOING PROVISIONS OF THIS PARAGRAPH, WHERE A PRODUCT IS SUPPLIED FOR BUSINESS PURPOSES, THE CONSUMER GUARANTEES UNDER THE CONSUMER GUARANTEES ACT 1993 (NZ) WILL NOT APPLY.

NEITHER THIS WARRANTY NOR ANY OTHER CONDITION OR WARRANTY BY CATERPILLAR, EXPRESS OR IMPLIED (SUBJECT ONLY TO THE MANDATORY RIGHTS), IS APPLICABLE TO ANY ITEM CATERPILLAR SELLS THAT IS WARRANTED DIRECTLY TO THE USER BY ITS MANUFACTURER.

IF THE MANDATORY RIGHTS MAKE CATERPILLAR LIABLE IN CONNECTION WITH SERVICES OR GOODS, THEN TO THE EXTENT PERMITTED UNDER THE MANDATORY RIGHTS, THAT LIABILITY SHALL BE LIMITED AT CATERPILLAR'S OPTION TO (a) IN THE CASE OF SERVICES, THE SUPPLY OF THE SERVICES AGAIN OR THE PAYMENT OF THE COST OF HAVING THE SERVICES SUPPLIED AGAIN AND (b) IN THE CASE OF GOODS, THE REPAIR OR REPLACEMENT OF THE GOODS, THE SUPPLY OF EQUIVALENT GOODS, THE PAYMENT OF THE COST OF SUCH REPAIR OR REPLACEMENT OR THE ACQUISITION OF EQUIVALENT GOODS.

CATERPILLAR EXCLUDES ALL LIABILITY FOR OR ARISING FROM ANY NEGLIGENCE ON ITS PART OR ON THE PART OF ANY OF ITS EMPLOYEES, AGENTS OR REPRESENTATIVES IN RESPECT OF THE MANUFACTURE OR SUPPLY OF GOODS OR THE PROVISION OF SERVICES RELATING TO THE GOODS.

CATERPILLAR IS NOT LIABLE FOR INCIDENTAL OR CONSEQUENTIAL DAMAGES UNLESS IMPOSED UNDER MANDATORY RIGHTS.

IF OTHERWISE APPLICABLE, THE VIENNA CONVENTION ON CONTRACTS FOR THE INTERNATIONAL SALE OF GOODS IS EXCLUDED IN ITS ENTIRETY.

C) For products supplied in Australia:

IF THE PRODUCTS TO WHICH THIS WARRANTY APPLIES ARE:

- I. PRODUCTS OF A KIND ORDINARILY ACQUIRED FOR PERSONAL, DOMESTIC OR HOUSEHOLD USE OR CONSUMPTION; OR**
- II. PRODUCTS THAT COST AUD 40,000 OR LESS,**

WHERE THOSE PRODUCTS WERE NOT ACQUIRED FOR THE PURPOSE OF RE-SUPPLY OR FOR THE PURPOSE OF USING THEM UP OR TRANSFORMING THEM IN THE COURSE OF PRODUCTION OR MANUFACTURE OR IN THE COURSE OF REPAIRING OTHER GOODS OR FIXTURES, THEN THIS SECTION C APPLIES.

THE FOLLOWING MANDATORY TEXT IS INCLUDED PURSUANT TO THE AUSTRALIAN CONSUMER LAW AND INCLUDES REFERENCES TO RIGHTS THE USER MAY HAVE AGAINST THE DIRECT SUPPLIER OF THE PRODUCTS: OUR GOODS COME WITH GUARANTEES THAT CANNOT BE EXCLUDED UNDER THE AUSTRALIAN CONSUMER LAW. YOU ARE ENTITLED TO A REPLACEMENT OR REFUND FOR A MAJOR FAILURE AND COMPENSATION FOR ANY OTHER REASONABLY FORESEEABLE LOSS OR DAMAGE. YOU ARE ALSO ENTITLED TO HAVE THE GOODS REPAIRED OR REPLACED IF THE GOODS FAIL TO BE OF ACCEPTABLE QUALITY AND THE FAILURE DOES NOT AMOUNT TO A MAJOR FAILURE. THE INCLUSION OF THIS TEXT DOES NOT CONSTITUTE ANY REPRESENTATION OR ACCEPTANCE BY CATERPILLAR OF LIABILITY TO THE USER OR ANY OTHER PERSON IN ADDITION TO THAT WHICH CATERPILLAR MAY HAVE UNDER THE AUSTRALIAN CONSUMER LAW.

TO THE EXTENT THE PRODUCTS FALL WITHIN THIS SECTION C BUT ARE NOT OF A KIND ORDINARILY ACQUIRED FOR PERSONAL, DOMESTIC OR HOUSEHOLD USE OR CONSUMPTION, CATERPILLAR LIMITS ITS LIABILITY TO THE EXTENT IT IS PERMITTED TO DO SO UNDER THE AUSTRALIAN CONSUMER LAW TO, AT ITS OPTION, THE REPAIR OR REPLACEMENT OF THE PRODUCTS, THE SUPPLY OF EQUIVALENT PRODUCTS, OR THE PAYMENT OF THE COST OF SUCH REPAIR OR REPLACEMENT OR THE ACQUISITION OF EQUIVALENT PRODUCTS.

THE WARRANTY SET OUT IN THIS DOCUMENT IS GIVEN BY CATERPILLAR INC. OR ANY OF ITS SUBSIDIARIES, 100 N. E. ADAMS ST, PEORIA, IL USA 61629, TELEPHONE 1 309 675 1000, THE USER IS RESPONSIBLE FOR ALL COSTS ASSOCIATED WITH MAKING A CLAIM UNDER THE WARRANTY SET OUT IN THIS DOCUMENT, EXCEPT AS EXPRESSLY STATED OTHERWISE IN THIS DOCUMENT, AND THE USER IS REFERRED TO THE BALANCE OF THE DOCUMENT TERMS CONCERNING CLAIM PROCEDURES, CATERPILLAR RESPONSIBILITIES AND USER RESPONSIBILITIES.

TO THE EXTENT PERMISSIBLE BY LAW, THE TERMS SET OUT IN THE REMAINDER OF THIS WARRANTY DOCUMENT (INCLUDING SECTION B) CONTINUE TO APPLY TO PRODUCTS TO WHICH THIS SECTION C APPLIES.

©2016 Caterpillar All Rights Reserved.

CAT, CATERPILLAR, their respective logos, "Caterpillar Yellow" the "Power Edge" trade dress as well as corporate and product identity used herein, are trademarks of Caterpillar and may not be used without permission.



Image shown might not reflect actual configuration

GCCP 1.2 - Control Panel

GCCP 1.2 is an auto Start Control Module suitable for a wide variety of diesel generator applications. Monitoring an extensive number of engine parameters, the modules will display warnings, shutdown and engine status information on the backlit LCD screen, illuminated LEDs and remote PC.

FEATURES

- 4-line back-lit LCD text display
- Multiple display languages
- Five-key menu navigation
- LCD alarm indication
- Customisable power-up text and images
- Data logging facility
- Internal PLC editor
- Protections disable feature
- Fully configurable via PC using USB & RS485 communication
- Front panel configuration with PIN protection
- Power save mode
- 3-phase generator sensing and protection
- Generator current and power monitoring (kW, kvar, kVA, pf)
- kW and kvar overload and reverse power alarms
- Over current protection
- Unbalanced load protection
- Breaker control via fascia buttons
- Fuel and start outputs configurable when using CAN
- Support for 0V to 10 V & 4 mA to 20 mA sensors
- 8 configurable digital inputs (3 available for Customer use)
- 8 configurable digital outputs (5 available for Customer use)
- 4 configurable analogue outputs (3 available for Customer Use)
- CAN, MPU and alternator frequency speed sensing in one variant
- Real time clock
- Engine pre-heat and post-heat functions
- Engine run-time scheduler
- Engine idle control for starting & stopping
- Fuel usage monitor and low fuel level alarms
- 3 configurable maintenance alarms

BENEFITS

- Hours counter provides accurate information for monitoring and maintenance periods
- User-friendly set-up and button layout for ease of use
- Multiple parameters are monitored & displayed simultaneously for full visibility
- The module can be configured to suit a wide range of applications for user flexibility
- PLC editor allows user configurable functions to meet user specific application requirements.
- RS485 Communication port can be used for the Remote Monitoring Communication (Compatible with Cat PLG)

SPECIFICATION

DC SUPPLY

CONTINUOUS VOLTAGE RATING

8 V to 35 V Continuous
5 V for upto 1 minute

CRANKING DROPOUTS

Able to survive 0 V for 100 ms, providing supply was at least 10 V before dropout and supply recovers to 5 V. This is achieved without the need for internal batteries.

LEDs and backlight will not be maintained during cranking.

MAXIMUM OPERATING CURRENT

260 mA at 12 V, 150 mA at 24 V

MAXIMUM STANDBY CURRENT

145 mA at 12 V, 85 mA at 24 V

CHARGE FAIL/EXCITATION RANGE

0 V to 35 V

GENERATOR & MAINS (UTILITY) VOLTAGE RANGE

15 V to 415 V AC (Ph to N)
26 V to 719 V AC (Ph to Ph)

FREQUENCY RANGE

3.5 Hz to 75 Hz

MAGNETIC PICKUP VOLTAGE RANGE

+/- 0.5 V to 70 V

FREQUENCY RANGE

10,000 Hz (max)

INPUTS

DIGITAL INPUTS A TO H

Negative switching

ANALOGUE INPUTS A & D

Configurable as:
Negative switching digital input 0 V to 10 V sensor
4 mA to 20 mA sensor Resistive sensor

ANALOGUE INPUTS B & C

Configurable as:
Negative switching digital input Resistive sensor

OUTPUTS

OUTPUT A & B (FUEL & START)

15 A DC at supply voltage

AUXILIARY OUTPUTS C, D, E, F, G & H

2 A DC at supply voltage

DIMENSIONS OVERALL

216 mm x 158 mm x 43 mm
8.5" x 6.2" x 1.5"

PANEL CUT-OUT

184 mm x 137 mm
7.2" x 5.3"

MAXIMUM PANEL THICKNESS

8 mm
0.3"

STORAGE TEMPERATURE RANGE

-40°C to +85°C
-40 °F to +185 °F

OPERATING TEMPERATURE RANGE

-30°C to +70°C
-22 °F to +158 °F

LEHE2017-01 (11-19)

www.Cat.com/electricpower

©2019 Caterpillar All rights reserved. Materials and specifications are subject to change without notice. The International System of Units (SI) is used in this publication. CAT, CATERPILLAR, their respective logos, "Caterpillar Yellow", the "Power Edge" and Cat "Modern Hex" trade dress as well as corporate and product identity used herein, are trademarks of Caterpillar and may not be used without permission.

AUTOMATIC VOLTAGE REGULATOR

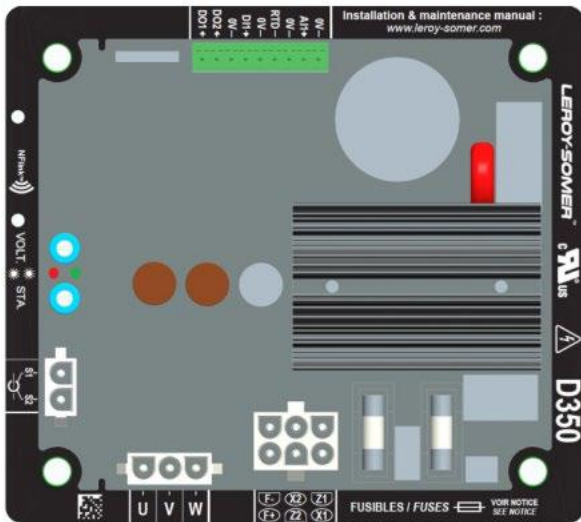

D350 AVR

The D350, Digital Voltage Regulator is used to regulate alternators with a field current of less than 5 A in continuous operations, and 10 A maximum in the event of short-circuit for 10 seconds maximum.

Its design is in accordance with mounting in a generator terminal box or a control cabinet. It is required, at a minimum, to follow the local protection and safety standards, especially those specific to electrical installations for voltages of 300 VAC phase-to-neutral maximum.

NFLink™ configuration module

The D350 is equipped with NFC technology for communication and configuration purposes. The configuration module is placed over the two dedicated positioning holes on the plastic enclosure as shown below. Once the configuration is done, the NF Link must be removed as it is not supposed to be left on the

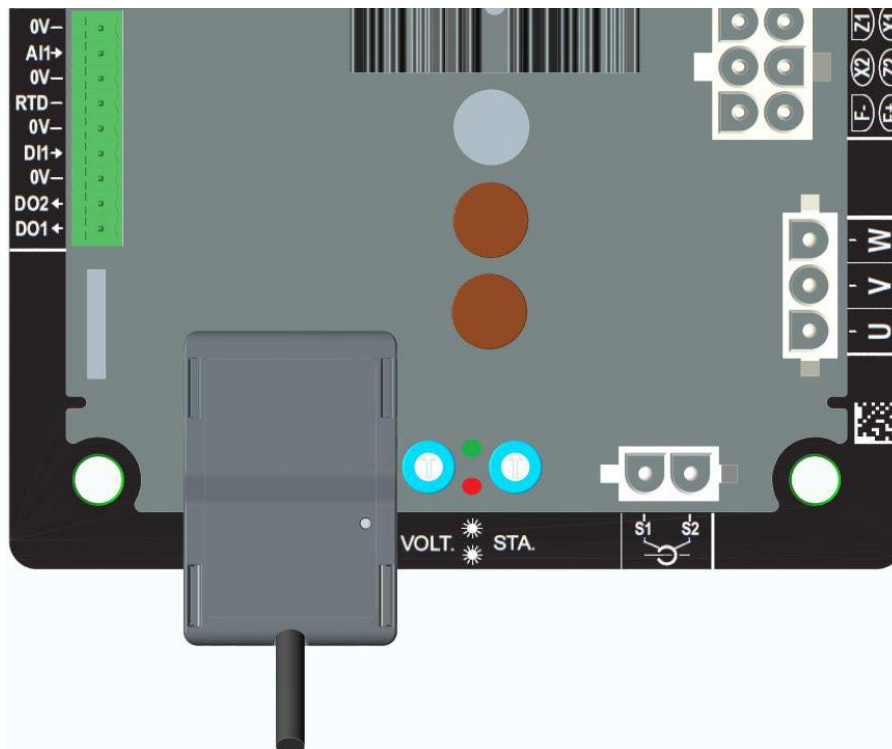

Technical characteristics

D350 regulator can be used to perform the following functions:

Voltage regulation

- With or without reactive droop compensation (Reactive droop to allow parallel operation)
- With or without line droop compensation.

Regulation of the field current, or manual mode, which allows direct control of the field current.

The D350 can also be used to:

- Adjust the reference for the regulation mode in progress, using an analogue input (0-10V and potentiometer)
- Monitoring of temperature sensor (Pt100 or CTP)
- Limit the minimum field current delivered to the exciter field
- Monitoring of the maximum stator current limit
- Loss of voltage sensing
- Withstand a sudden short-circuit for 10 seconds maximum in AREP, PMG
- Signals monitoring (events logger).
- 2 digital outputs for various trip, regulation mode and measurement data

Alternator voltage sensing:

- 3 phases without neutral, 2 phases or 1 phase with neutral
- Three-phase range 0-530VAC
- Consumption < 2VA

Stator current measurement with CT:

- Range 0-1A or 0-5A
- Consumption < 2VA

Power supply:

- 4 terminals for PMG, AREP, SHUNT
- Range 50-277 VAC
- Consumption max < 3000VA

Field excitation:

- Rated 0-5 A
- Short-circuit 10A max.
- Field winding resistance > 4 ohms

Frequency:

- Range 10-100Hz

AUTOMATIC VOLTAGE REGULATOR



- Regulation accuracy: +/-0.25% of the average of the three phases on a linear load, with harmonic distortion less than 5%
- Voltage adjustment range: 0 to 150% of the rated voltage
- Quadrature droop adjustment range: -20% to 20%
- Under frequency protection: integrated, adjustable threshold, slope adjustable from 0.5 to 3V/Hz in steps of 0.1 V/Hz
- Excitation ceiling: adjustable by configuration at 3 points
- Environment: ambient temperature from -40°C to +65°C, relative humidity of less than 95% non-condensing, mounted in a cabinet or in a terminal box

Easy Reg Advanced:

- All the D350 settings are entered / configured using the "EasyReg Advanced" software.
- This program is only compatible with computers running WINDOWS® versions Windows 7 and Windows 10 operating systems.

Dimensions:

- Height : 52.9mm
- width : 125mm
- Length : 140mm

Mounting:

- Holes spacing on the Length : 115mm
- Holes spacing on the width: 100mm

Weight: 0.45kg

Conformity to standards

- EMC: IEC 61000-6-2, IEC 61000-6-4
- Humidity: IEC 60068-1 and test in accordance with IEC 60068-2-14
- Dry heat: IEC 60068-2-2
- Damp heat: IEC 60028-2-30
- Cold: IEC 600068-2-1

AUTOMATIC VOLTAGE REGULATOR



D350 AVR and NFLink™ Dimensions

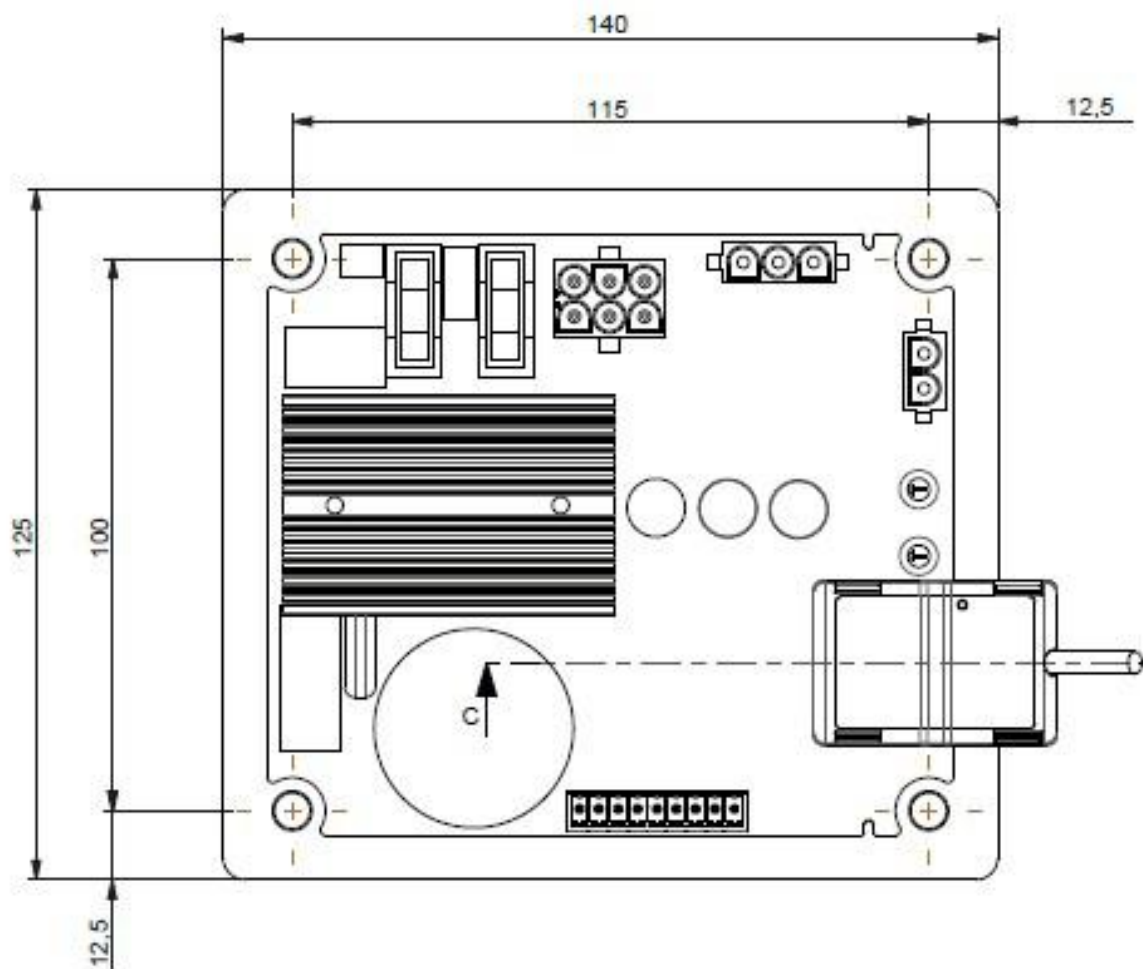
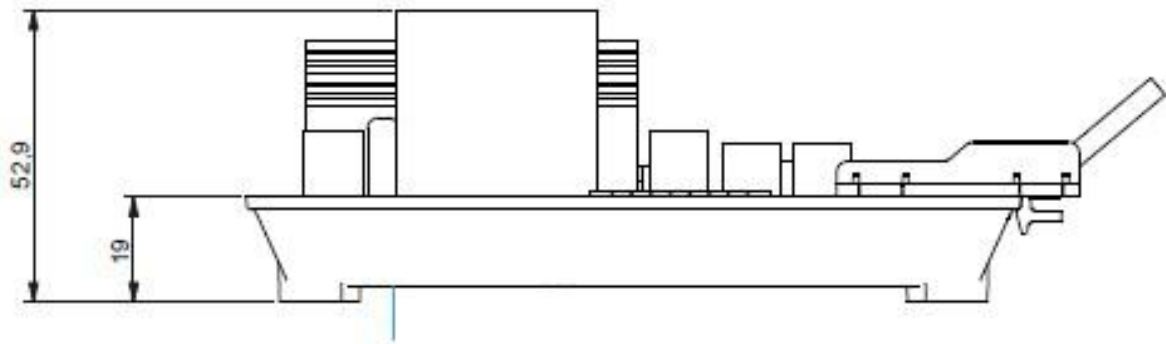

LEHE1923-00 (05-19)

www.Cat.com/electricpower

©2019 Caterpillar All rights reserved. Materials and specifications are subject to change without notice. The International System of Units (SI) is used in this publication. CAT, CATERPILLAR, their respective logos, "Caterpillar Yellow", the "Power Edge" and Cat "Modern Hex" trade dress as well as corporate and product identity used herein, are trademarks of Caterpillar and may not be used without permission.

C9 ACERT™, C13 ACERT, C15 ACERT, C18 ACERT Circuit Breakers

Manually Operated Circuit Breakers

Current (A)	Frame	Number of Poles	Interrupting Ratings (kA rms)			Trip Units	(Lugs) Cable Size Range / Phase	Auxiliary Options
			240V	480V	600V			
100	H	3	65	35	18	Electronic LSI	8-30 AWG	Form C (1NO + 1NC) Shunt Trip 24VDC
250	J	3	65	35	18		(2) 3/0 – 250 kcmil	
400	T5N	3	65	25	18	Electronic LSI/I (S or I) or LSI	(2) 3/0 – 250 kcmil	1 Form C + 1 Bell Alarm 250VAC/VDC Shunt Trip 24VDC
600	T6N	3	65	35	20		(3) 2/0 – 400 kcmil	
800	T6N	3	65	35	20		(3) 2/0 – 400 kcmil	1 Form C + 1 Bell Alarm 400VAC / 250VDC Shunt Trip 24VDC
1200	T7S	3	65	50	25		(4) 2/0 – 500 kcmil	
1600	R	3	65	35	18	Electronic LSI	BUS BAR	Form C (1NO + 1NC) Shunt Trip 24VDC
2000	R	3	65	35	18		BUS BAR	
2500	R	3	65	35	18		BUS BAR	
3000	R	3	65	35	18		BUS BAR	

Electrically Operated Circuit Breakers

Current (A)	Frame	Number of Poles	Interrupting Ratings (kA rms)			Trip Units	(Lugs) Cable Size Range / Phase	Auxiliary Options
			240V	480V	600V			
800	T 7M-S	3	65	50	25	Electronic LSI	(4) 4/0 – 500 kcmil	2 Form C + 1 Bell Alarm 24VDC
1200	T 7M-S	3	65	50	25	Electronic LSI	(4) 4/0 – 500 kcmil	2 Form C + 1 Bell Alarm 24VDC
2000	T8M-S	3	125	125	100	Electronic LSI	BUS BAR	2 Form C + 1 Bell Alarm 24VDC
3000	T8M-S	3	125	125	100	Electronic LSI	BUS BAR	2 Form C + 1 Bell Alarm 24VDC

Single Breaker Options (250 – 3000A)

Model	Current (A)	Operation
C9 ACERT™	250	Manually Operated
C9 ACERT	400	Manually Operated
C9 ACERT, C13 ACERT, C15 ACERT, C18 ACERT	600	Manually Operated
C9 ACERT, C13 ACERT, C15 ACERT, C18 ACERT	800	Manually Operated or Electrically Operated
C9 ACERT, C13 ACERT, C15 ACERT, C18 ACERT	1200	Manually Operated or Electrically Operated
C13 ACERT, C15 ACERT, C18 ACERT	1600	Manually Operated
C15 ACERT, C18 ACERT	2000	Manually Operated or Electrically Operated
C18 ACERT	2500	Manually Operated
C18 ACERT	3000	Manually Operated or Electrically Operated

Multiple Breaker Options

Model	Main Breaker Box		Auxiliary Box
	1st Breaker (Amps)	2nd Breaker (Amps)	Breaker (Amps)
	Manually Operated	Manually Operated	Manually Operated
C9 ACERT, C13 ACERT, C15 ACERT, C18 ACERT	250	250, 400, 600, 800, or 1200	3rd Breaker: 250 or 400 (Not available if 1st & 2nd Breaker = 1200A)
C9 ACERT, C13 ACERT, C15 ACERT, C18 ACERT	400		
C9 ACERT, C13 ACERT, C15 ACERT, C18 ACERT	600		
C9 ACERT, C13 ACERT, C15 ACERT, C18 ACERT	800		
C9 ACERT, C13 ACERT, C15 ACERT, C18 ACERT	1200		
C13 ACERT, C15 ACERT, C18 ACERT	1600	Not Available	2nd Breaker: 250 or 400
C15 ACERT, C18 ACERT	2000		
C18 ACERT	2500		
C18 ACERT	3000		

H-Frame Circuit Breakers

Electronic Trip Unit Long Time / Short Time Trip Curve

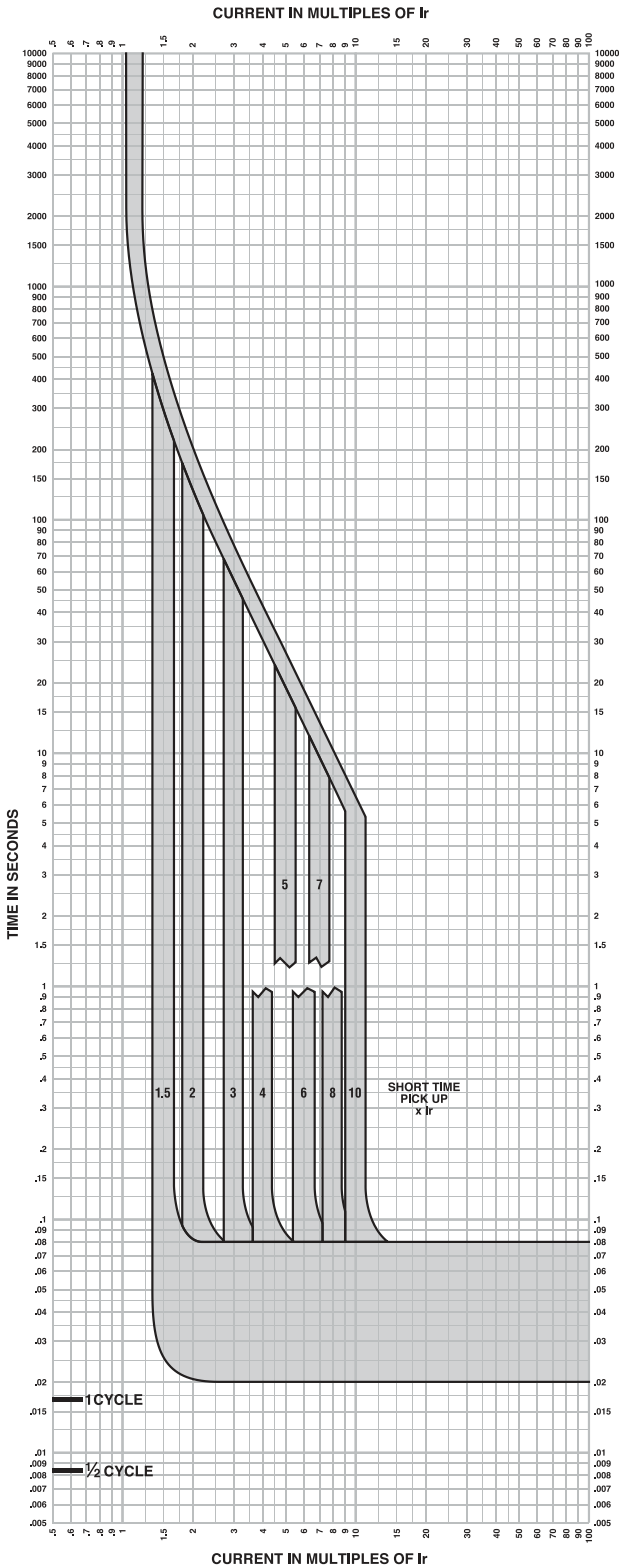

**Long Time/Short Time Trip Curve
60A, 100A, 150A H-Frame**

The time-current curve information is to be used for application and coordination purposes only.

Notes:

1. There is a thermal-imaging effect that can act to shorten the long-time delay. The thermal imaging effect comes into play if a current above the long-time delay pickup value exists for a time and then is cleared by the tripping of a downstream device or the circuit breaker itself. A subsequent overload will cause the circuit breaker to trip in a shorter time than normal. The amount of time delay reduction is inverse to the amount of time that has elapsed since the previous overload. Approximately 20 minutes is required between overloads to completely reset thermal-imaging.
2. Total clearing times shown include the response times of the trip unit, the circuit breaker opening, and the extinction of the current.

Curves apply from -35°C to +70°C (-31°F to +158°F) ambient temperature.

H-Frame Circuit Breakers

Electronic Trip Unit Instantaneous Trip Curve

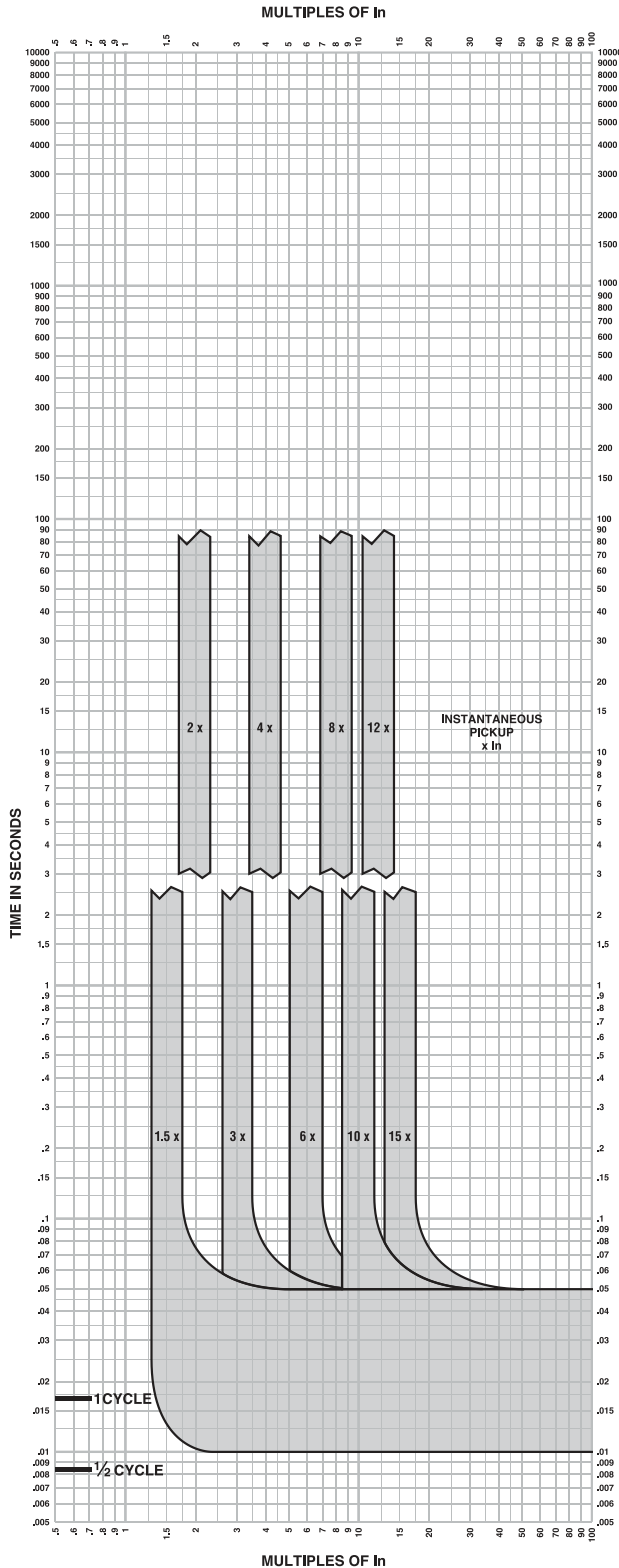

Instantaneous Trip Curve 60A, 100A, 150A H-Frame

The time-current curve information is to be used for application and coordination purposes only.

Notes:

1. There is a thermal-imaging effect that can act to shorten the long-time delay. The thermal imaging effect comes into play if a current above the long-time delay pickup value exists for a time and then is cleared by the tripping of a downstream device or the circuit breaker itself. A subsequent overload will cause the circuit breaker to trip in a shorter time than normal. The amount of time delay reduction is inverse to the amount of time that has elapsed since the previous overload. Approximately 20 minutes is required between overloads to completely reset thermal-imaging.
 2. Total clearing times shown include the response times of the trip unit, the circuit breaker opening, and the extinction of the current.
 3. In = Maximum dial setting of Ir.
 60A H-Frame: In = 60A = Max Ir setting
 100A H-Frame: In = 100A = Max Ir setting
 150A H-Frame: In = 150A = Max Ir setting
- Curves apply from -35°C to +70°C (-31°F to +158°F) ambient temperature.

J-Frame 250 A Typical Peak Let-Through Curves

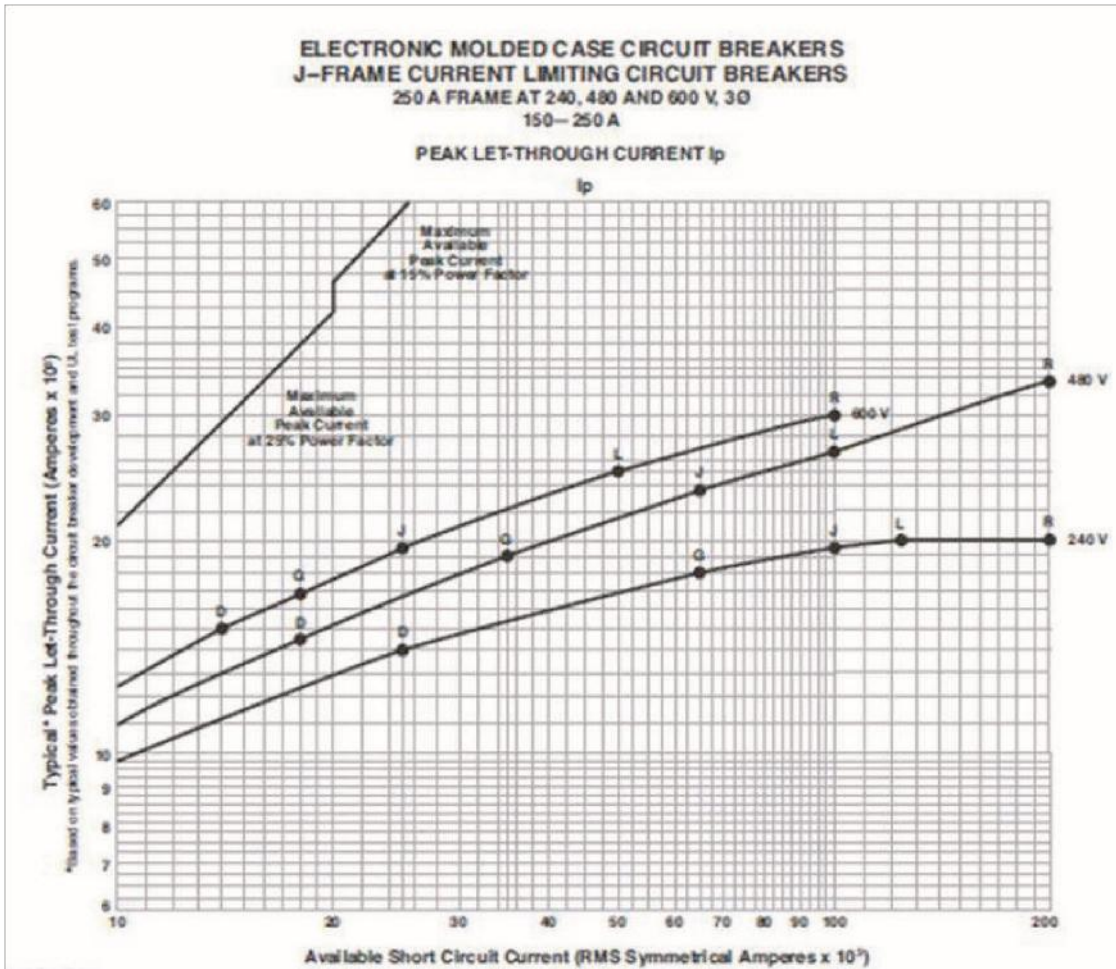

Figure 1

J-Frame 150-250 A (JD, JG, JJ, JL, and JR) Thermal-Magnetic Trip

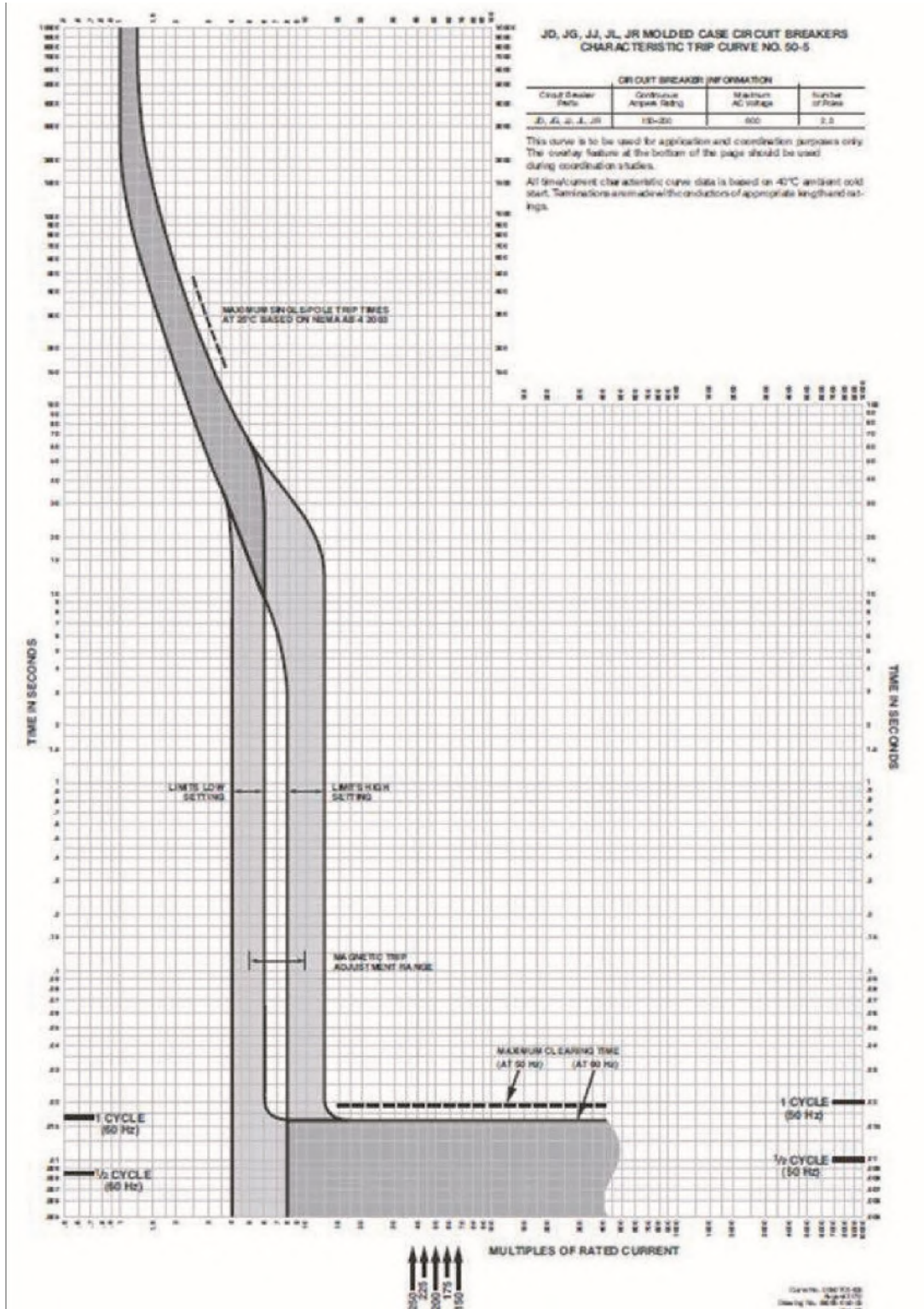

Figure 2

Ground Fault Module GFM250JD Trip Curve

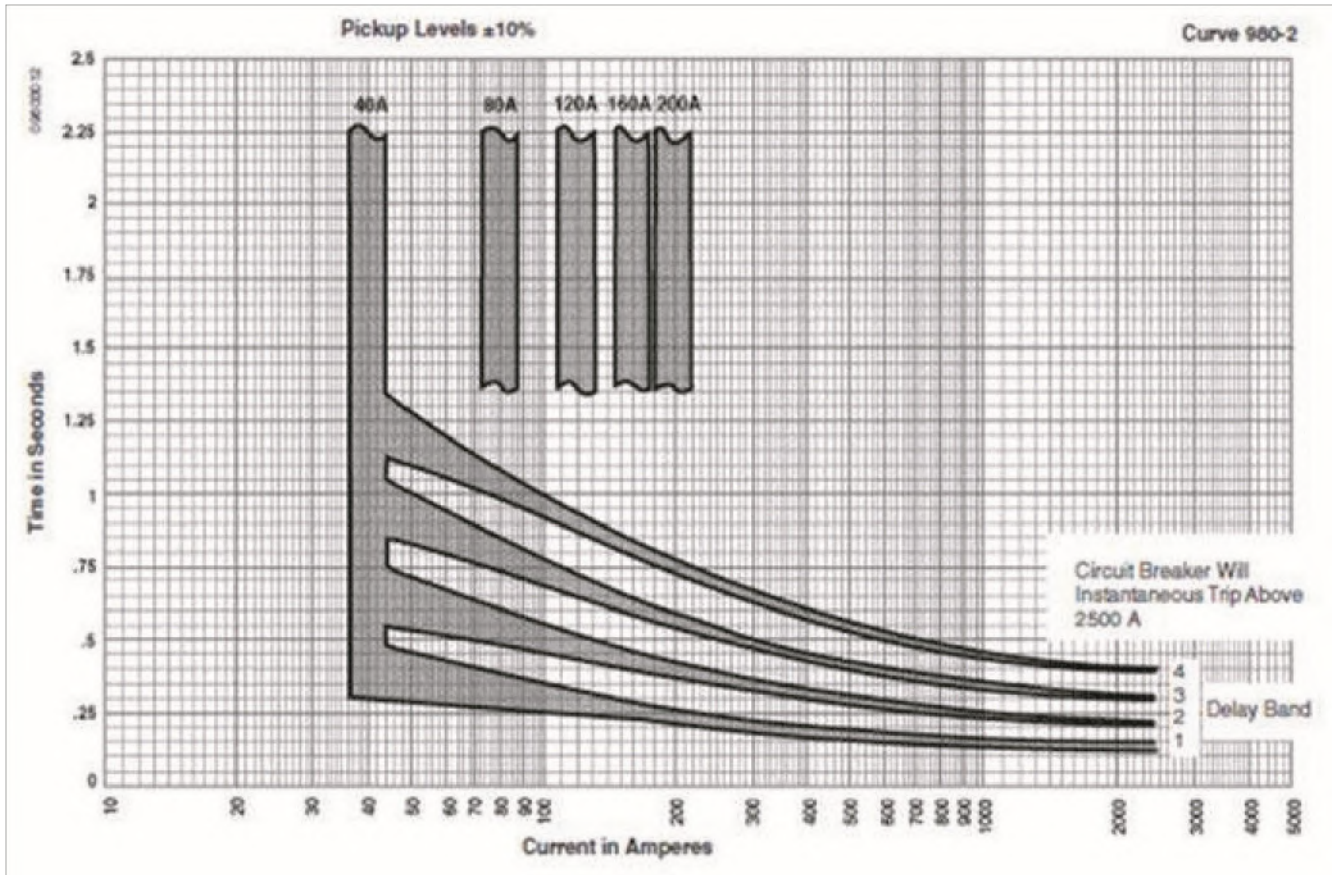

Figure 3

T6 600 / 800 -PR221DS L-1 Functions

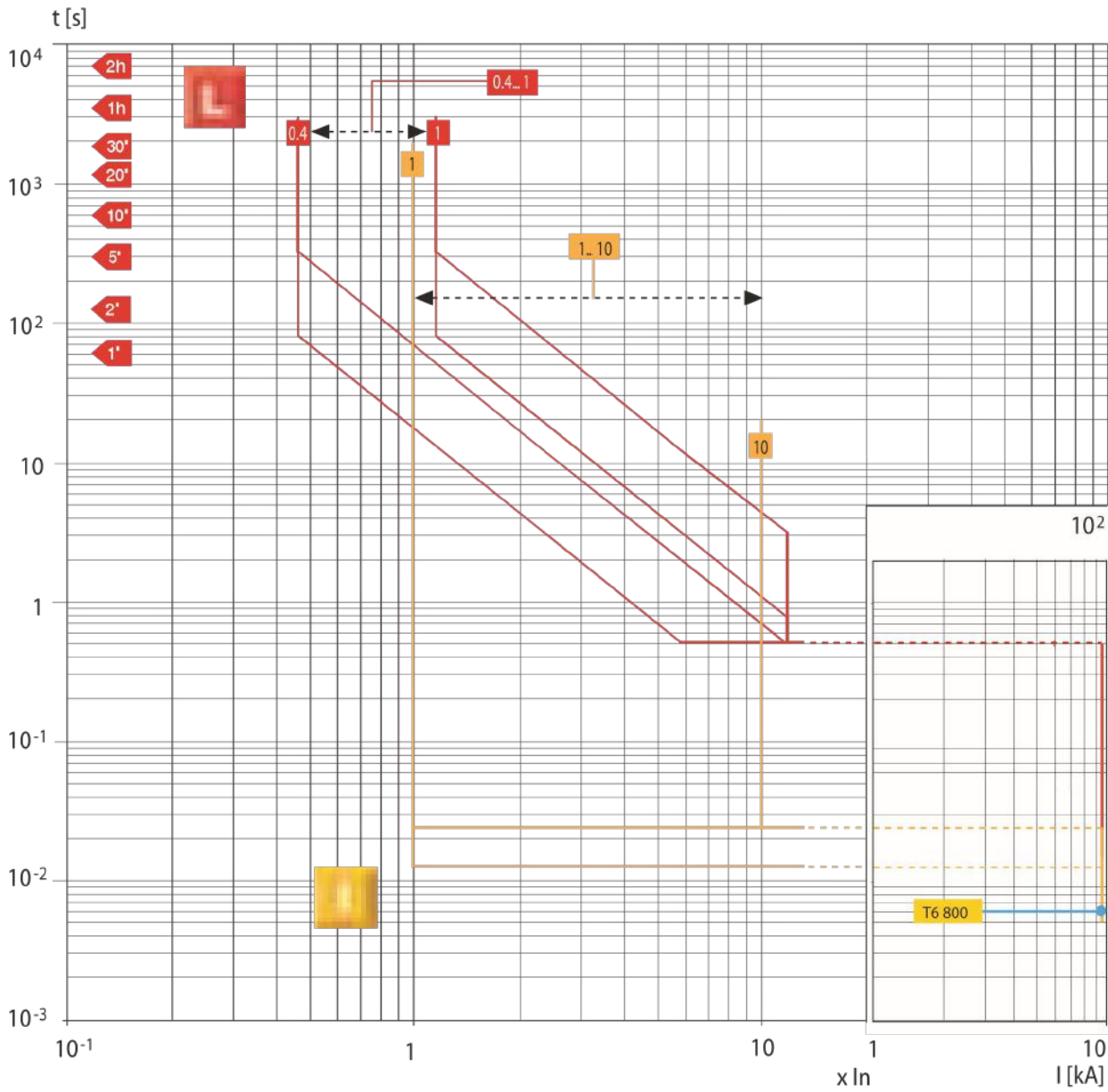

Figure 4

T6 600 / 800 -PR221DS L-S Functions

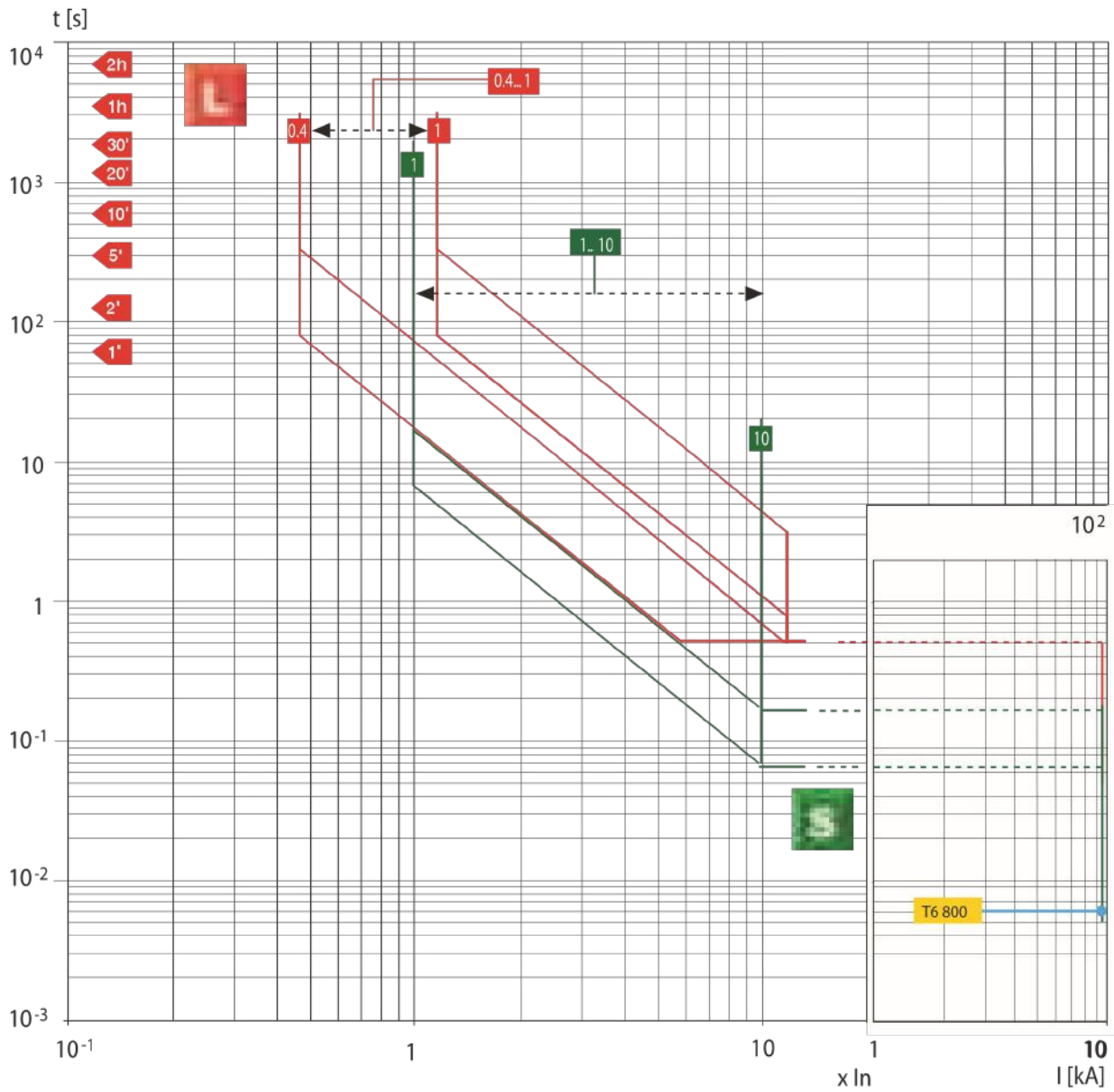

Figure 5

Tmax T7 PR231/P Functions

L-S Functions

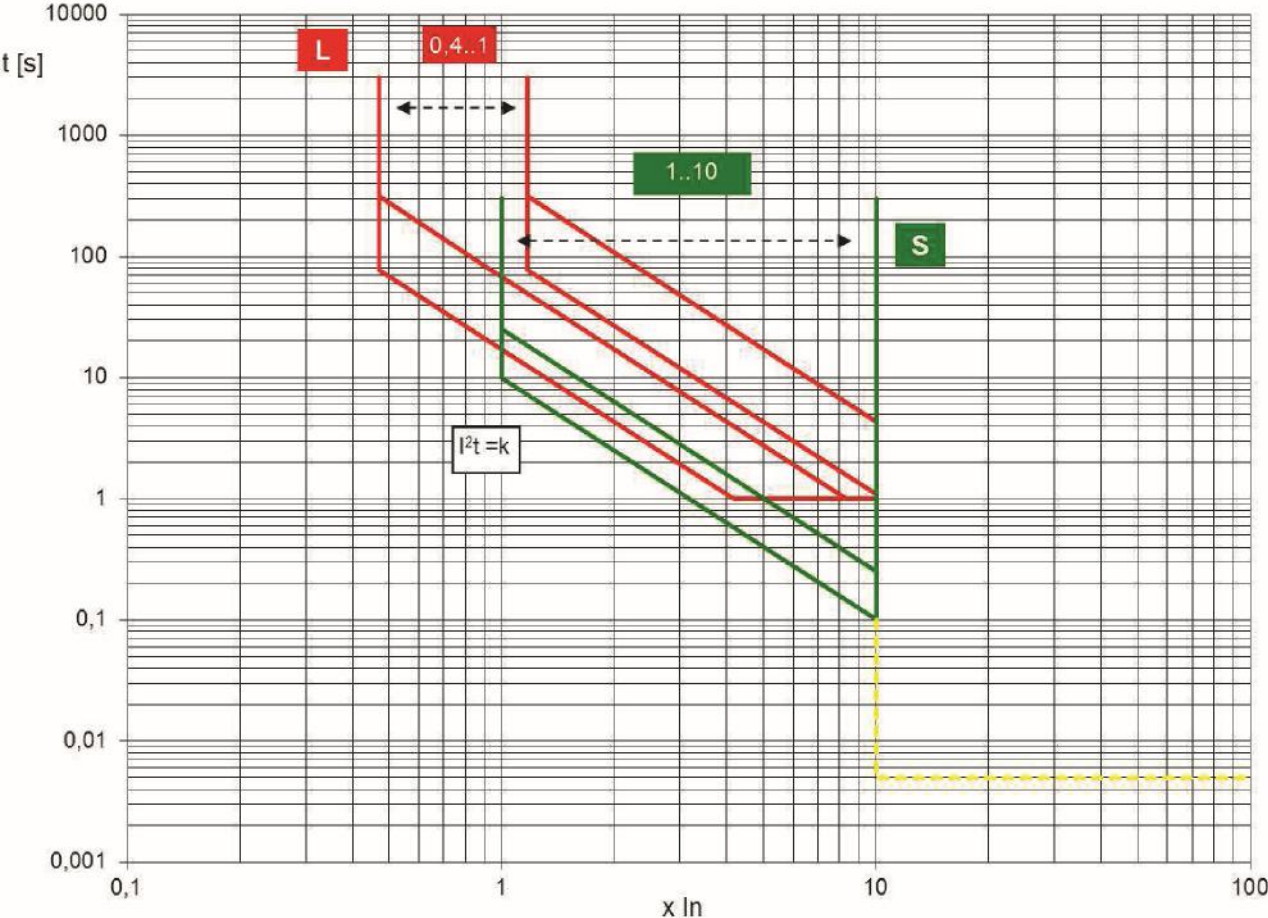

Figure 7

T6 800 - PR222DS and PR222DS/PD-A L-S-I Functions

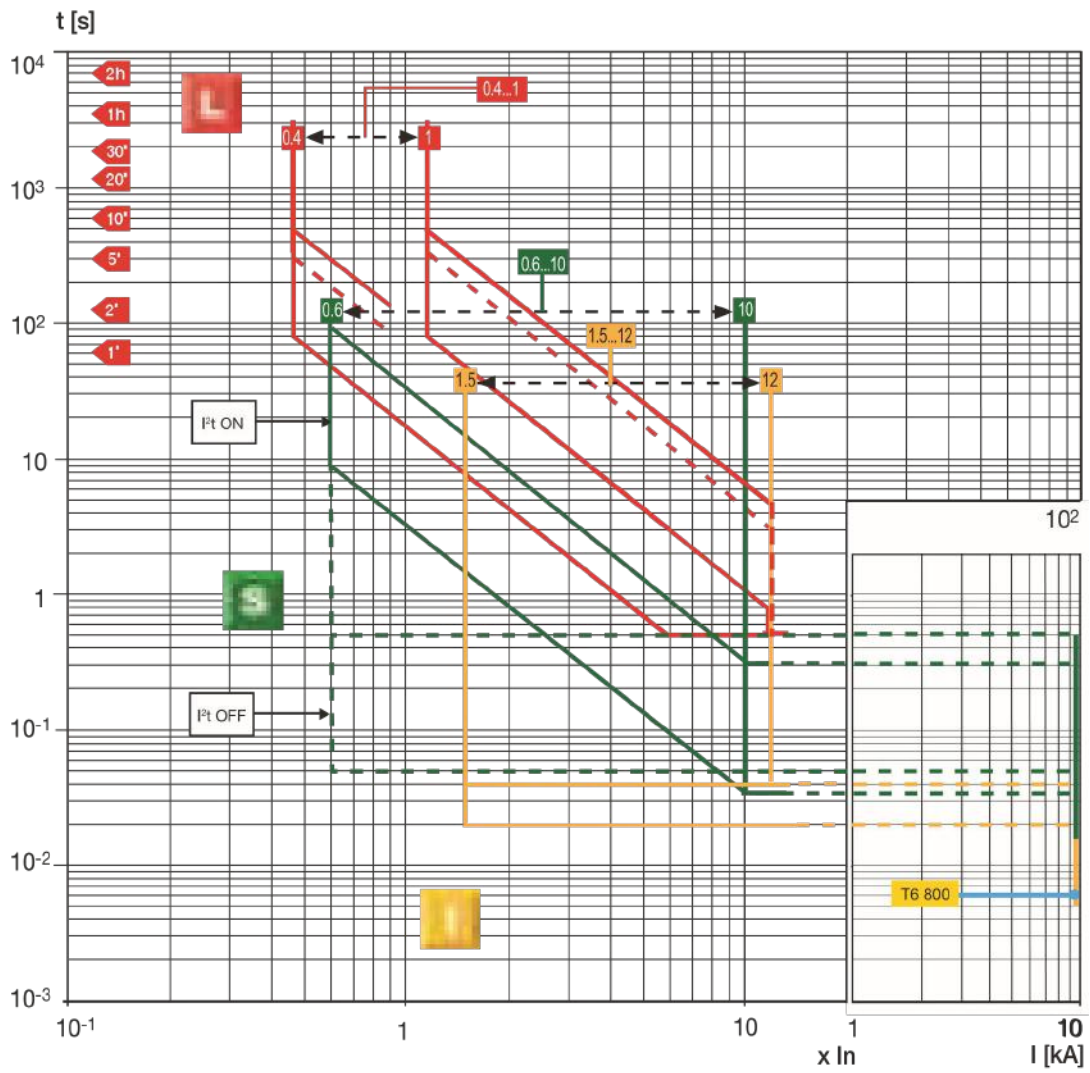

Figure 8

T7 1000/1200 - PR232/P
L-S-I Functions

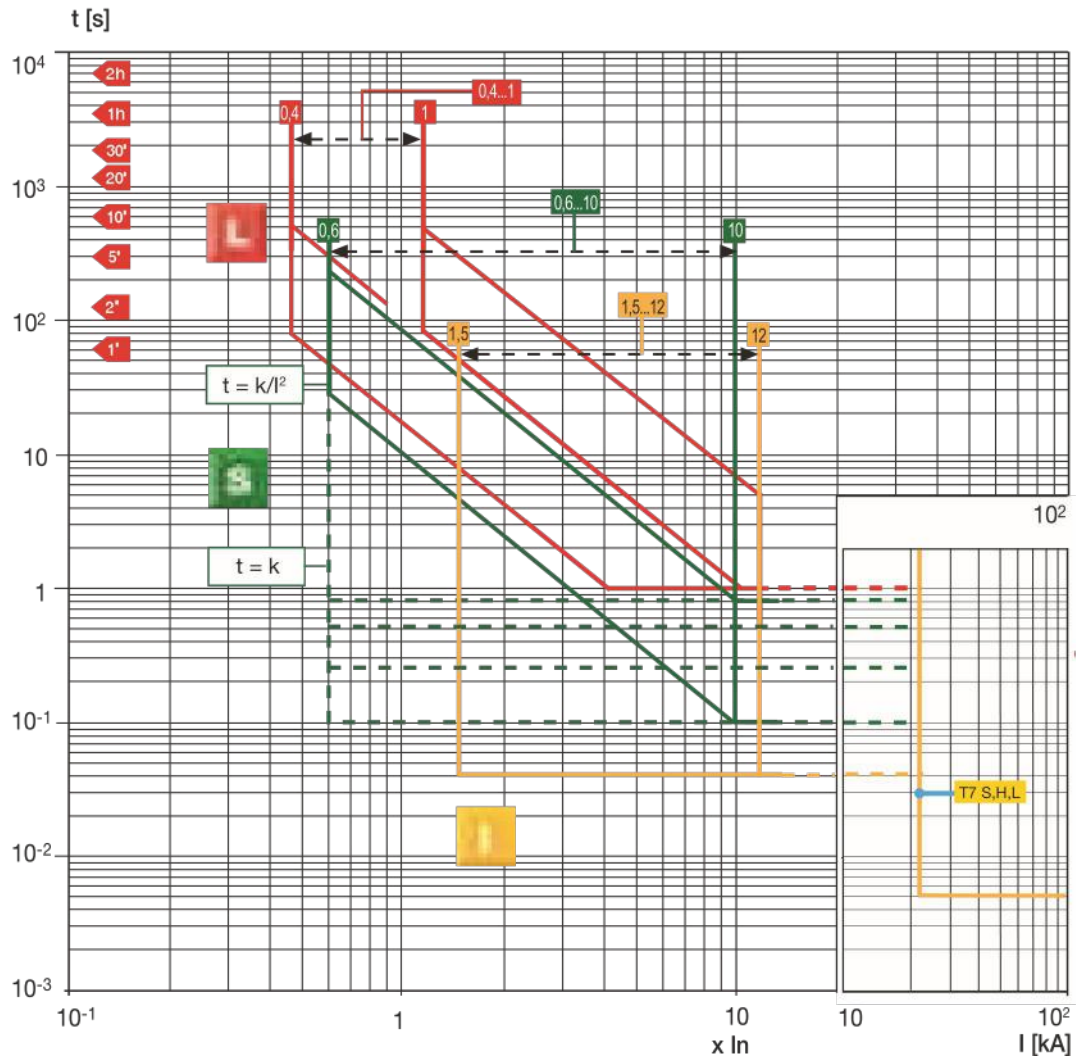

Figure 9

T7 1000/1200 - PR332/P L-S-I Functions

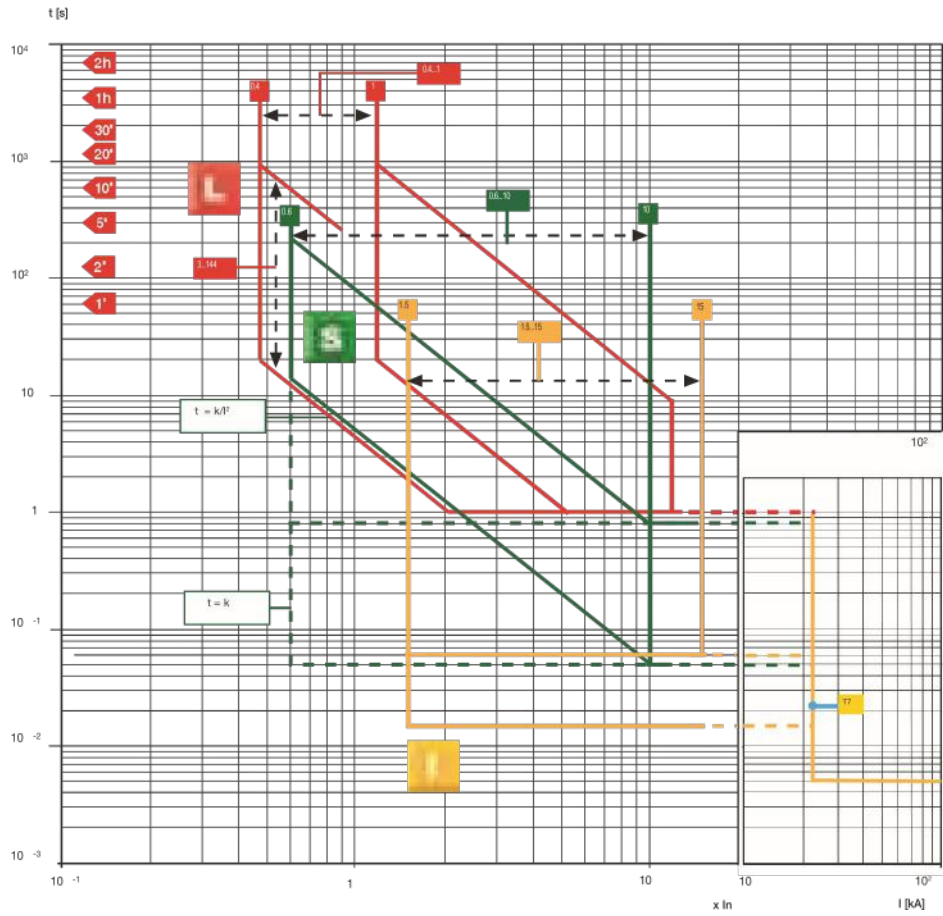

Figure 10

Circuit Breakers



T8 1600/2000/2500/3000 – PR232/P-T8
 L-S-I Functions

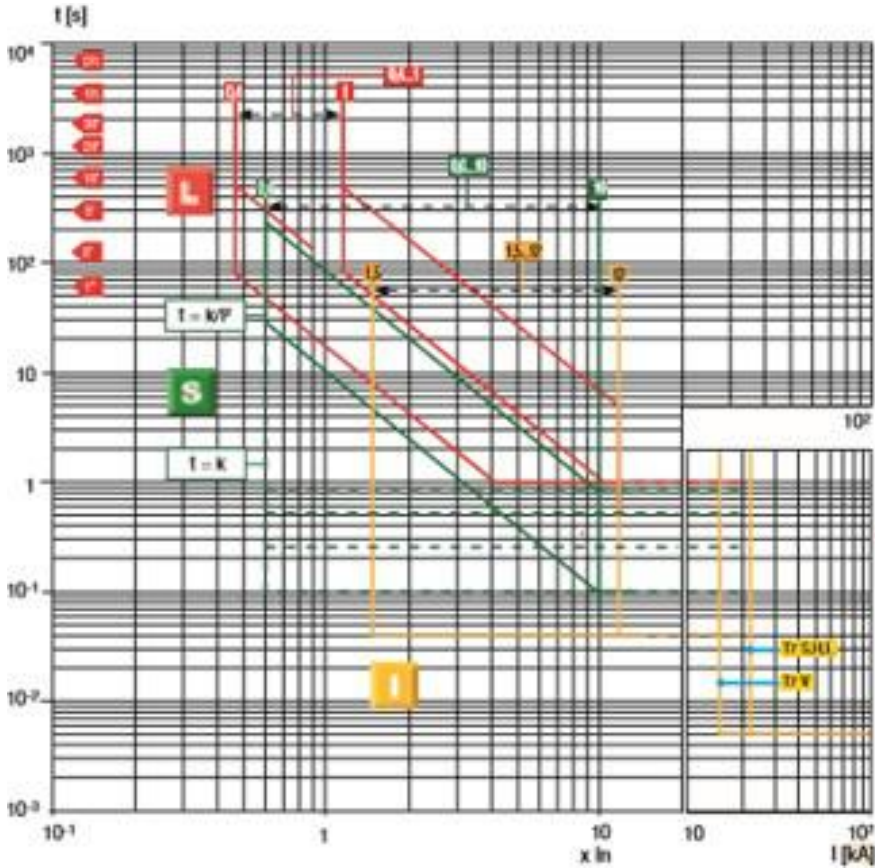

Figure - 11

P, R, NS-Frame Long-Short Trip Curve and NW-Frame Long-Short Trip Curve

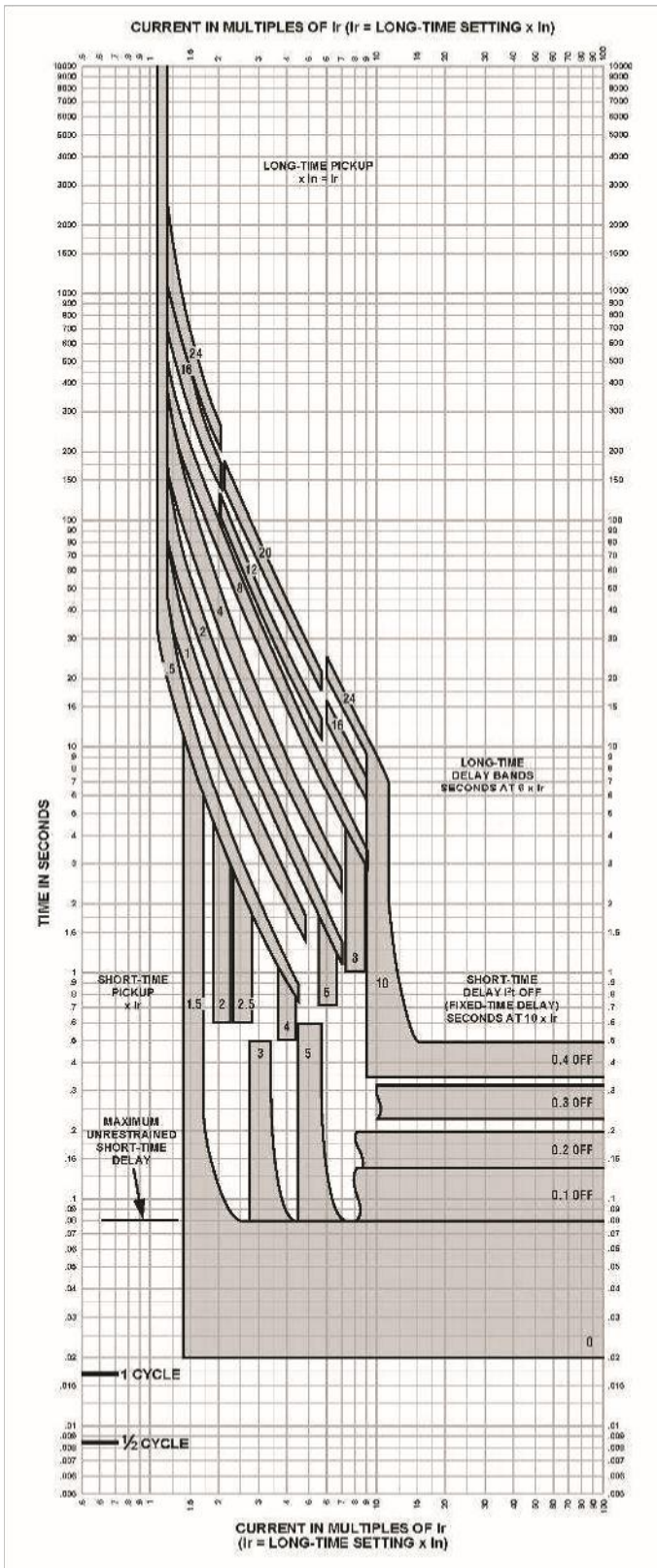

Figure - 12

Long-time Pickup and Delay Short-time Pickup and I²t OFF Delay

The time-current curve information is to be used for application and coordination purposes only. Curves apply from -30°C to +60°C ambient temperature.

Notes:

1. There is a thermal-imaging effect that can act to shorten the long-time delay. The thermalimaging effect comes into play if a current above the long-time delay pickup value exists for a time and then is cleared by the tripping of a downstream device or the circuit breaker itself. A subsequent overload will cause the circuit breaker to trip in a shorter time than normal. The amount of time delay reduction is inverse to the amount of time that has elapsed since the previous overload. Approximately 20 minutes is required between overloads to completely reset thermal-imaging.
2. The end of the curve is determined by the interrupting rating of the circuit breaker.
3. With zone-selective interlocking on, short-time delay utilized and no restraining signal, the maximum unrestrained short-time delay time band applies regardless of the setting.
4. Total clearing times shown include the response times of the trip unit, the circuit breaker opening, and the extinction of the current.
5. For a withstand circuit breaker, instantaneous can be turned OFF. See Page 22 for instantaneous trip curve. See tables on pages 03-18 for instantaneous override values..
6. Overload indicator illuminates at 100%.

P, R, NS-Frame Instant Curve and NW-Frame Instant Trip Curve

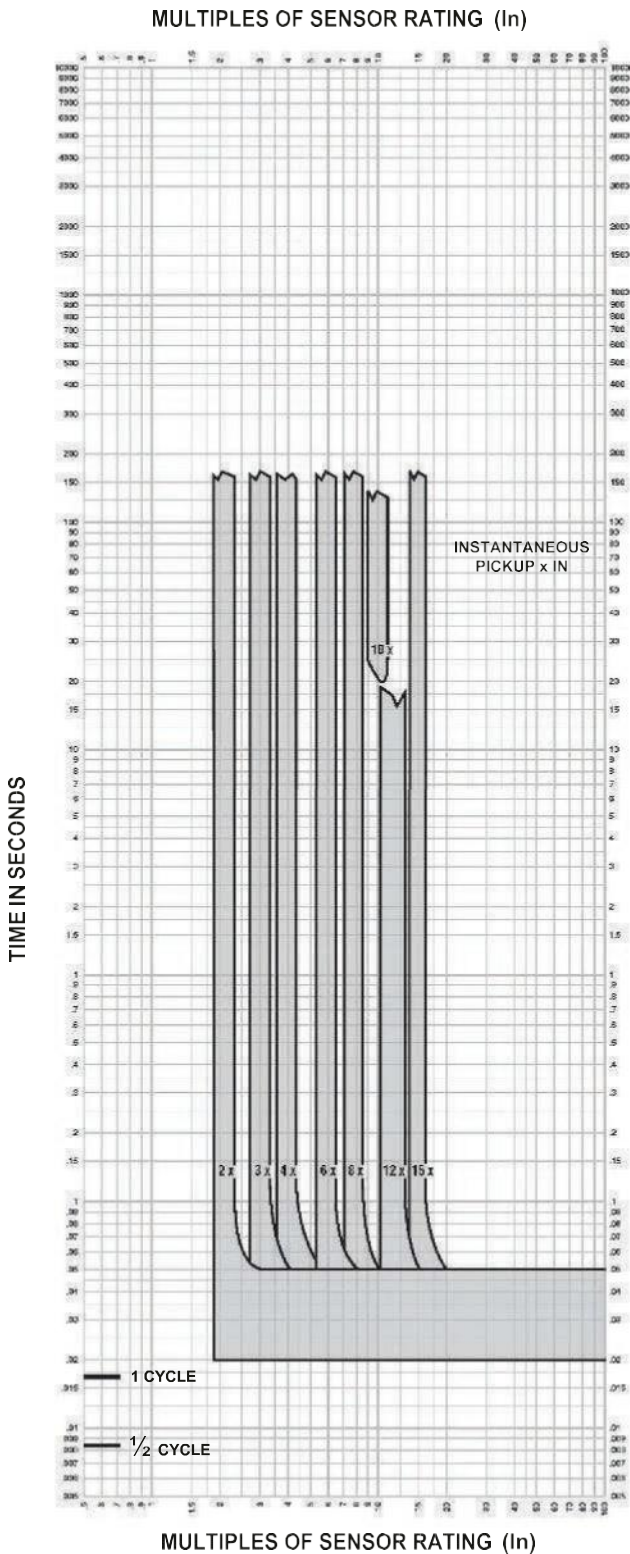

Figure 13

Instantaneous Pickup 2x–15x and OFF

The time-current curve information is to be used for application and coordination purposes only.

Curves apply from -30° to +60°C ambient temperature.

Notes:

1. The end of the curve is determined by the interrupting rating of the circuit breaker.
2. Total clearing times shown include the response times of the trip unit, the circuit breaker opening, and the extinction of the current.
3. The instantaneous region of the trip curve shows maximum total clearing times. Actual clearing times in this region can vary depending on the circuit breaker mechanism design and other factors. The actual clearing time can be considerably faster than indicated. Contact your local Sales Office for additional information.
4. For a withstand circuit breaker, instantaneous can be turned OFF. See tables on pages 03-18 for instantaneous override values.
5. See page 22 for long-time pickup, long-time delay, short-time pickup, and short time delay trip curves.

P, R, NS-Frame Ground Curve and NW-Frame Ground Fault Trip Curve

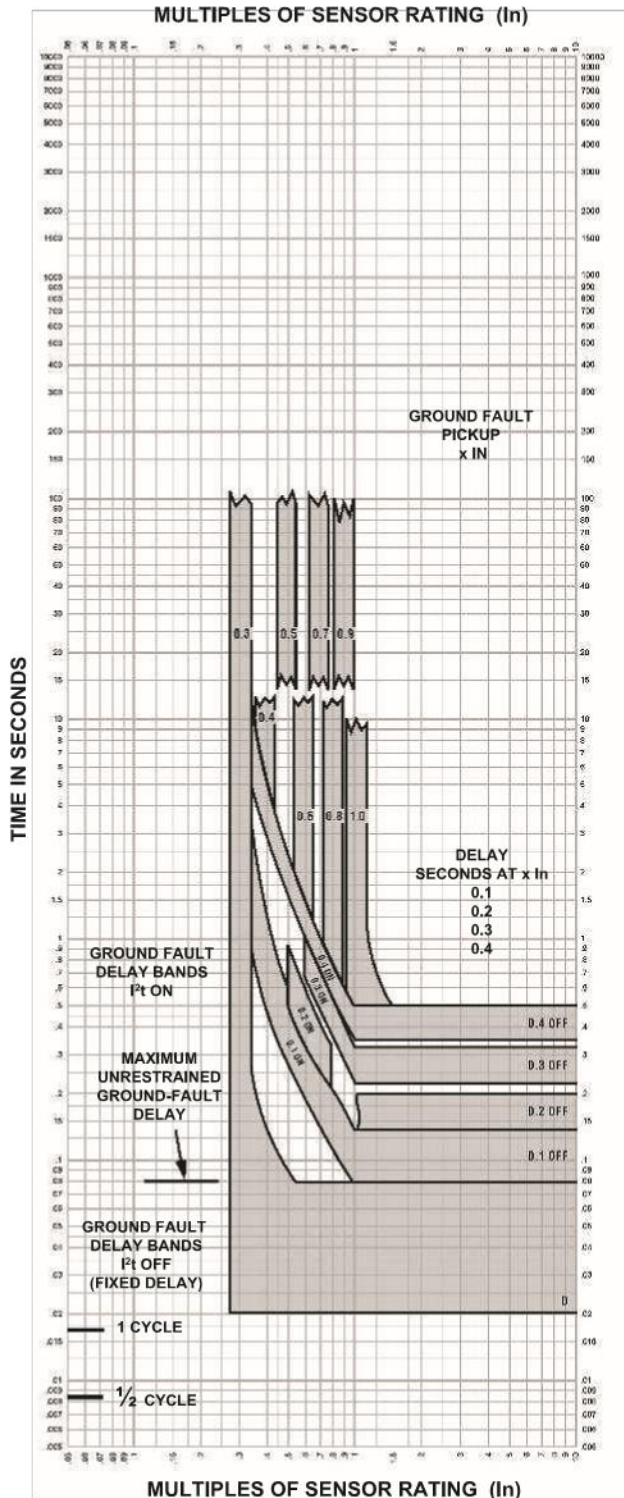

Ground-fault I²t OFF and ON In ≤ 400 A

The time-current curve information is to be used for application and coordination purposes only.

Curves apply from -30°C to +60°C ambient temperature.

Figure 14

LET'S DO THE WORK.™

LEHE0942-05 (10-19)

www.Cat.com/electricpower

©2019 Caterpillar. All rights reserved. Materials and specifications are subject to change without notice. CAT, CATERPILLAR, their respective logos, ADEM, S•O•S, LET'S DO THE WORK, "Caterpillar Yellow", the "Power Edge" trade dress as well as corporate and product identity used herein, are trademarks of Caterpillar and may not be used without permission.

Note : The Information on this Document comes from a Third Party Supplier and is not a Caterpillar Material



Image shown might not reflect actual configuration

SPECIFICATION

AC SUPPLY

VOLTAGE RANGE 90 V to 305 V (L-N)

FREQUENCY RANGE

48 Hz to 64 Hz (L-N)

DC OUTPUT RATING

10 A DC at 24 V DC

RIPPLE AND NOISE

<1%

EFFICIENCY

>86%

REGULATION LINE

<0.5%

LOAD

2%

TEMPERATURE SENSOR INPUT

PT1000

PROTECTIONS

Short Circuit
DC Over Voltage
DC Over Current
Reverse Polarity
Over Temperature
AC Under & Over Voltage

CHARGE FAILURE RELAY

3 A at 30 V DC volt free relay

DIMENSIONS OVERALL

70 mm x 200 mm x 130 mm
2.7" x 7.9" x 5.1"

WEIGHT

0.75 kg

OPERATING TEMPERATURE RANGE

-30 °C to +80 °C
-22 °F to +176 °F

STORAGE TEMPERATURE RANGE

-40 °C to +70 °C
-22 °F to +158 °F

BATTERY CHARGER

The intelligent battery charger has been developed with safety, usability, optimised battery performance and maximum battery lifetimes in mind.

A comprehensive range of input and output protections ensures a continued safe charging environment also enabling the use of the charger as a power supply.

FEATURES

- Intelligent two, three and four stage charging profiles
- Configurable to suit most battery types (12V/24V)
- Adjustable current limit
- Can be used as a battery charger, power supply or both at the same time
- Automatic or Manual boost and storage charge functions to help maintain battery condition
- Digital Microprocessor Technology
- Temperature compensation for battery charging
- Low Output Ripple and superb line regulation
- Three LED Indicators
- AC input Under voltage
- AC input Over voltage
- Battery charger output Over voltage
- Battery charger output Over current
- Optional battery temperature compensation with over temperature protection
- Output short circuit and Inversion polarity with auto recovery
- Configurable charge termination

Automatic Boost Mode

- Boosts and equalises cell charge improving battery performance and life

Power Save Mode

- Once the battery is fully charged the chargers switch to Eco-Power to save energy

Communication

- Can be integrated into external systems through MODBUS RTU using RS485
- Fully configurable via PC Software
- External remote LCD option

BENEFITS

- Fully flexible to maximise the life of the battery
- Suitable for a wide range of battery types
- Switched mode design
- Minimum 86% efficiency throughout full operating range
- No external intervention for boost mode
- Multiple chargers can be linked together to provide larger current output
- Can be permanently connected to battery and mains (utility) supply. No need to disconnect through high load conditions.

LEHE2022-01 (09-19)

www.Cat.com/electricpower

©2019 Caterpillar All rights reserved. Materials and specifications are subject to change without notice. The International System of Units (SI) is used in this publication. CAT, CATERPILLAR, their respective logos, "Caterpillar Yellow", the "Power Edge" and Cat "Modern Hex" trade dress as well as corporate and product identity used herein, are trademarks of Caterpillar and may not be used without permission.



Jacket Water Heater (WHHH01)

Appropriate when the generator set is to be sited in a low ambient environment, the heater maintains the engine coolant at a temperature [typically 38°C (100°F)] which facilitates rapid starting and load acceptance. The heater assembly uses UL compliant components (to UL1030) and has CSA certification which is to both CSA and UL Standards.

The heater itself is powered by a 240V for 60 Hz AC auxiliary supply. A thermostatic controller is included to regulate the output temperature to within safe limits. When the generator set is not running the heater is automatically connected to the AC supply through a power relay mounted in the control panel.

Features

- Uniform heat distribution
- Reduces wear from cold spots
- Improves startability
- Thermostatically controlled and protected
- 6' (1.8m) cord
- Ensures generator is at optimal starting temperature and ready to accept load
- Durable pump with non-magnetic impeller that does not attract metal debris
- Robust die cast aluminum housing improves sealing of the hoses, eliminates leaking and breakage
- Corrosion resistant steel brackets for superior strength and durability
- Reduces thermal stress on coolant hoses
- Element designed for long life with maximum heat transfer
- IP44 Ingress Protection Rating
- No evaporation of coolant from hoses
- Reduces low coolant level alarms because coolant does not boil

Part No	Outlet Location	Watts	Volts	Amps	Regulating Thermostat	Safety Thermostat
577-1758/577-9355	Right	2700	240	11.25	On 90°F (32°C) Off 115°F (46°C)	210°F (98°C)

www.cat.com/electricpower

©2019 Caterpillar
All rights reserved.

Information contained in this publication may be considered confidential. Discretion is recommended when distributing. Materials and specifications are subject to change without notice.

CAT, CATERPILLAR, LET'S DO THE WORK, their respective logos, "Caterpillar Yellow," the "Power Edge" and Cat "Modern Hex" trade dress as well as corporate and product identity used herein, are trademarks of Caterpillar and may not be used without permission.

100 Amp Load Center



Image shown may not reflect actual package

Specifications

Number of spaces	6
Number of circuits	12
Number of tandem circuit breakers	6
System voltage	120/240VAC
NEMA degree of protection	NEMA 3R outdoor
Electrical connection	Lugs
Wiring configuration	3-wire
Material	Tin plated aluminum busbar
Enclosure material	Welded galvanized steel
Cover finish	Gray baked enamel
Product certifications	UL E-6294

www.cat.com/electricpower

©2019 Caterpillar
All rights reserved.

Information contained in this publication may be considered confidential. Discretion is recommended when distributing. Materials and specifications are subject to change without notice.

CAT, CATERPILLAR, LET'S DO THE WORK, their respective logos, "Caterpillar Yellow," the "Power Edge" and Cat "Modern Hex" trade dress as well as corporate and product identity used herein, are trademarks of Caterpillar and may not be used without permission.



Image shown might not reflect actual configuration

Remote Annunciator Module

It is an LED expansion module that can be used with compatible control modules. The module has been designed to display a maximum of eight individual LED indications up to a maximum distance of 1 KM (0.6miles).

The Annunciator will consist of two modules to provide a 16 Channel Fault annunciation.

It is presented in a vertical enclosure. It includes an alarm sounder that is triggered when the host controller detects an alarm condition. The alarm can be muted using the front push button.

The Panels will be fitted with removable label cards which can be used to identify the standard NFPA alarms. If desired

It includes individual LEDs for each channel and a 'Power On' LED that flashes when the link with the host controller is lost.

FEATURES

- The Remote annunciator has an integral Sounder /Horn
- Eight configurable LEDs (per module)
- Works up to 1 KM (0.6 miles) from the host controller
- A single Controller can support five Caterpillar Configured remote annunciator control boxes

ENVIRONMENTAL TESTING STANDARDS

ELECTRO-MAGNETIC COMPATIBILITY

BS EN 61000-6-2
EMC Generic Immunity Standard for the Industrial Environment
BS EN 61000-6-4
EMC Generic Emission Standard for the Industrial Environment

ELECTRICAL SAFETY

BS EN 60950
Safety of Information Technology Equipment, including Electrical Business Equipment

TEMPERATURE

BS EN 60068-2-1
Ab/Ae Cold Test -30 °C BS EN 60068-2-2
Bb/Be Dry Heat+70°C

VIBRATION

BS EN 60068-2-6
Ten sweeps in each of three major axes
5 Hz to 8 Hz @ +/-7.5 mm, 8 Hz to 500 Hz @ 2 gn

SHOCK

BS EN 60068-2-27
Three shocks in each of three major axes 15 gn in 11 Ms

HUMIDITY

BS EN 60068-2-30
Db Damp Heat Cyclic 20/55 °C @ 95% RH 48 Hours
BS EN 60068-2-78
Cab Damp Heat Static 40 °C @ 93% RH 48 Hours

DEGREES OF PROTECTION PROVIDED BY ENCLOSURES BS EN 60529

IP65 - Front of module when installed into the control panel with the supplied sealing gasket.

SPECIFICATION

CONTINUOUS VOLTAGE RATING

8 V to 35 V Continuous

CRANKING DROPOUTS

Able to survive 0 V for 50 mS, providing supply was at least 10 V before dropout and supply recovers to 5 V. This is achieved without the need for internal batteries. LEDs and backlight will not be maintained during cranking.

MAXIMUM OPERATING CURRENT

112 mA at 12 V, 53 mA at 24 V

MAXIMUM STANDBY CURRENT

74 mA at 12 V, 35 mA at 24 V

DIMENSIONS OVERALL

275.5 mm x 214.2 mm x 108.8 mm
10.85" x 8.43" x 4.28"

MAXIMUM PANEL THICKNESS

8 mm
0.3"

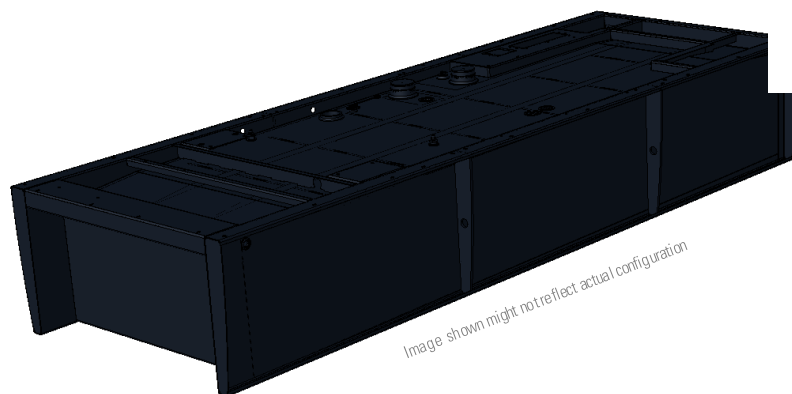

INTEGRAL FUEL TANKS DE250 GC – DE600 GC

FEATURES

- UL Listed for United States (UL 142) and Canada (CAN/ULC S601)
- Facilitates compliance with NFPA 30 code, NFPA 37 and 110 standards and CSA C282 code
- Dual wall
- Low fuel level warning standard, customer configurable warning or shutdown
- Primary tank leak detection switch in containment basin
- Tank design provides capacity for thermal expansion of fuel
- Fuel supply dip tube is positioned so as not to pick up fuel sediment
- Fuel return and supply dip tube is separated by an internal baffle to prevent immediate re-supply of heated return fuel
- Pressure washed with an iron phosphate solution
- Interior tank surfaces coated with a solvent-based thin-film rust preventative
- Heavy gauge steel gussets with internal lifting rings
- Primary and secondary tanks are leak tested at 20.7 kPa (3 psi) minimum
- Compatible with open packages and enclosures
- Gloss black polyester alkyd enamel exterior paint
- Welded steel containment basin (minimum of 110% of primary tank capacity)
- Direct reading fuel gauge with variable electrical output
- Emergency vents on primary and secondary tanks are sized in accordance with NFPA 30.

INTEGRAL

- Integral diesel fuel tank is incorporated into the generator set base frame
- Robust base design includes linear vibration isolators between tank base and engine generator.

OPTIONS

- Audio/visual fuel level alarm panel
- 5gal (18.9 L) spill containment
- Locking Fuel Fill
- Overfill prevention Valve

Integral Fuel Tank Base Useable Capacities with Fuel Tank Dimensions & Weights

Standby ekW	Width mm	Width in
250-300	1430	56.3
350-400	1630	64.1
450-500	1630	64.1
550-600	1865	73.4

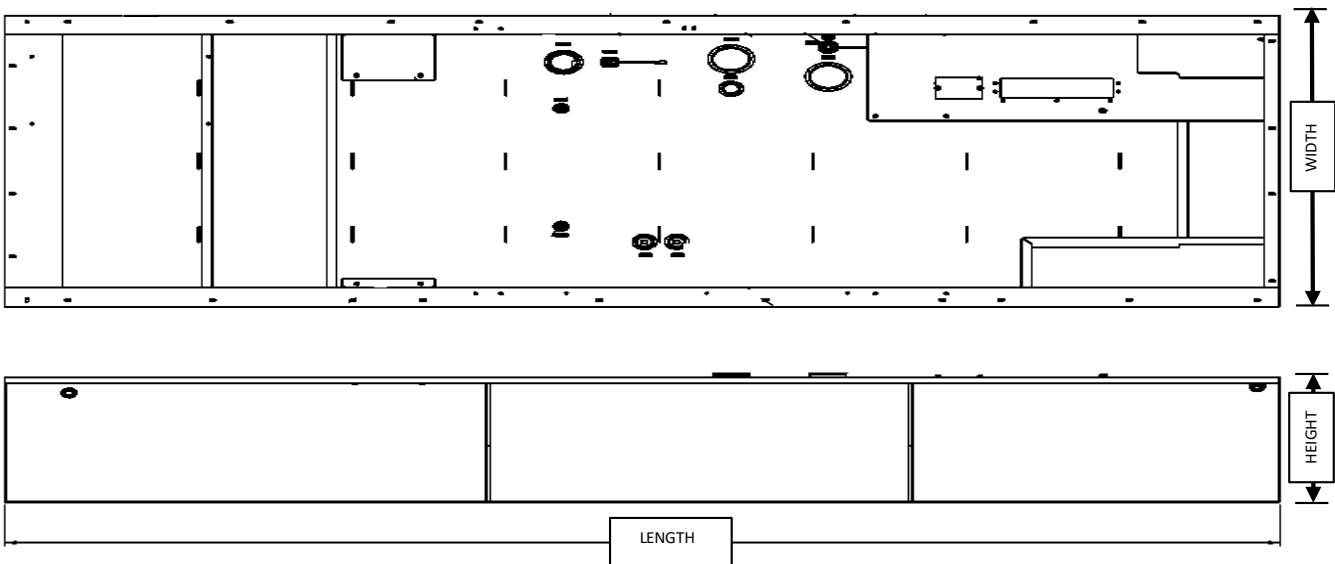

The heights listed above do not include lumber used during manufacturing and shipping

A. Open Set & Sound Attenuated Enclosure

Tank Design	Feature Code	Total Capacity		Useable Capacity		Tank Only						Overall Package Height with Tank			
						Dry Weight		Height 'H'		Length 'L'		Open		Enclosure	
		Litre	Gallon	Litre	Gallon	kg	lb	mm	in	mm	in	mm	in	mm	in
Integral Tank	FTDW035	2270.7	599.8	2059.9	543.9	970	2138	762.4	30.0	3958	155.8	2202	86.7	2487	97.9
	FTDW036	2820	744.9	2553	674.4	1165	2568	818.8	32.2	4815	189.5	2584	101.7	2644	104
	FTDW037	3671	969.7	3323	877.8	1331	2934	668.2	26.3	4622	181.9	2456	96.7	2644	104
	FTDW038	4292	1133.8	3889	1027.3	1657	3653	816.4	32.1	4980	196	2560	100.7	2172	85.5

B. Estimated Run Time (Hours)

Tank Design	Feature Code	Standby Ratings (kVA)						
		ekW	100%		75%		50%	
			Hrs	L/hr	Hrs	L/hr	Hrs	L/hr
Integral Tank	FTDW035	250	28.1	73.3	35	58.8	47	43.8
		300	24	86.0	30.8	66.8	40	51.5
	FTDW036	350	27.1	94.3	31.2	81.9	42.4	60.2
		400	24.1	105.9	28.1	90.7	38.6	66.2
	FTDW037	450	25.2	131.7	31.3	106.1	42.0	79.1
		500	24.3	137	30.1	110.5	46.6	71.3
	FTDW038	550	25.7	151.1	32.9	118.1	45.2	86.1
		600	24.1	161.6	30.0	129.6	42.4	91.7

Tanks with full electrical stub-up area include removable end channel. Tanks with RH stub-up include stubup area directly below the circuit breaker or power terminal strips.

Fuel tanks and applicable options facilitate compliance with the following United States NFPA Code and Standards:

NFPA 30: Flammable and Combustible Liquids Code

NFPA 37: Standard for the Installation and Use of Stationary Combustion Engines and Gas Turbines

NFPA 110: Standard for Emergency and Standby Power Systems

Fuel tanks and applicable options facilitate compliance with the following Canadian Standard and Code:

CSA C282 – Emergency Electrical Power Supply for Buildings

CSA B139-09 – Installation Code for Oil-Burning Equipment

LET'S DO THE WORK.™

LEHE2015-00 (07-19)

www.Cat.com/electricpower

©2019 Caterpillar. All rights reserved. Materials and specifications are subject to change without notice. The International System of Units (SI) is used in this publication. CAT, CATERPILLAR, their respective logos, "Caterpillar Yellow", the "Power Edge" and Cat "Modern Hex" trade dress as well as corporate and product identity used herein, are trademarks of Caterpillar and may not be used without permission.

SOUND ATTENUATED LEVEL 2

ENCLOSURES

D250GC – D600GC

60 Hz



Image shown might not reflect actual configuration

FEATURES

Robust / Highly Corrosion Resistant Construction

- Factory installed on skid base or tanks base
- Environmentally friendly, polyester powder baked paint
- Enclosure constructed with 18-gauge steel
- Interior zinc plated fasteners
- Internally mounted exhaust silencing system
- Comply with ASCE/SEI 7 for Wind loads up to 100mph
- Designed and tested to comply with UL 2200 Listed generator set package

Excellent Access

- Large cable entry area for installation ease.
- Accommodates side mounted single or multiple breakers.
- Two doors on both sides.
- Vertically hinged allow 180° opening rotation
- Radiator fill cover.

Security and Safety

- Lockable access doors which give full access to control panel and breaker.
- Cooling fan and battery charging alternator fully guarded.
- Fuel fill, oil fill and battery can only be reached via lockable access.
- Externally mounted emergency stop button (Optional).
- Designed for spreader bar lifting to ensure safety.
- Stub-up area is rodent proof.

Sound Attenuated Level 2

- Caterpillar white paint
- UL Listed integral fuel tank with 24 hours running time capacity (Optional).
- DC lighting package (Optional)

Enclosure Package Operating Characteristics

Enclosure Type	Standby ekW	Cooling Air Flow Rate		Ambient Capability*		Sound Pressure Levels (dBA) at 7m (23 ft)
		m ³ /s	cfm	°C	°F	100% Load
Level 2 Sound Attenuated Enclosure (Steel)	250	6.4	13561	57	135	74
	300	6.4	13561	51	125	74
	350	7.4	15680	57	134	71
	400	7.4	15680	53	127	71
	450	8.4	17692	54	130	73
	500	8.4	17692	50	122	73
	550	11.2	23731	56	133	73
	600	11.2	23731	53	127	73

*Cooling system performance at sea level. Consult your Cat[®] dealer for site specific ambient and altitude capabilities.

Note: Sound level measurements are subject to instrumentation, installation and manufacturing variability, as well as ambient site conditions.

DIMENSIONS

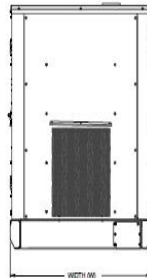
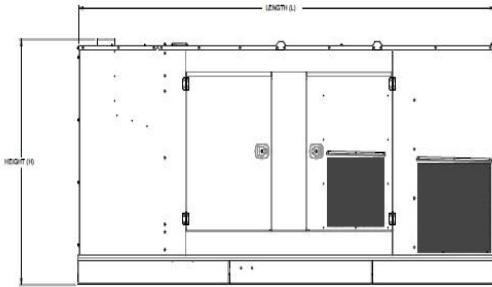

Sound Attenuated Enclosure on Skid Base

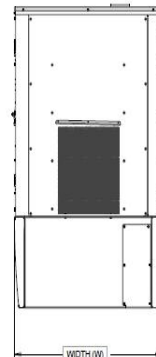
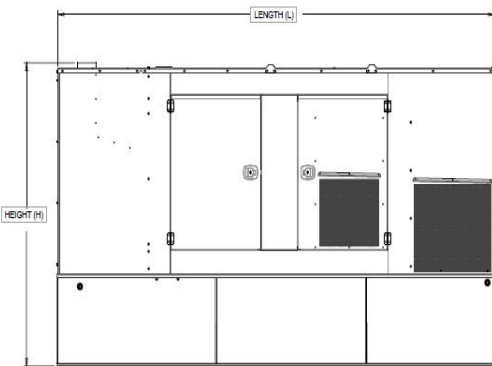

Sound Attenuated Enclosure on a UL Listed Integral Fuel Tank Base

Image shown might not reflect actual configuration

WEIGHTS & DIMENSIONS

Enclosure Type	Standby Ratings, ekW	Length, L		Width, W		Height, H		Package Weights	
		mm	in	mm	in	mm	in	kg	lb
Sound Attenuated Enclosure on Skid Base	250	3958	155.8	1440	56.7	1991	78.4	2857	6298.6
	300							2945	6492.6
	350	4633	182.4	1630	64.2	2227	87.7	3983	8781.0
	400							4017	8856.0
	450	4823	189.8	1630	64.2	2777	109.3	4408	9718.0
	500							4457	9826.0
	550	4980	196.1	1865	73.4	2723	107.2	4754	10480.8
	600							4837	10663.8
Sound Attenuated Enclosure on UL Listed Integral Fuel Tank Base	250	3958	155.8	1440	56.7	2487	97.9	3497	7709.6
	300							3585	7903.6
	350	4633	182.4	1630	64.2	2644	104.1	4765	10505.0
	400							4799	10580.0
	450	4823	189.8	1630	64.2	2777	109.3	5345	11783.7
	500							5394	11891.7
	550	4980	196.1	1865	73.4	2723	107.2	5973	13168.2
	600							6056	13351.2

LET'S DO THE WORK.™

LEHE2014-02 (09-19)

www.Cat.com/electricpower

©2019 Caterpillar All rights reserved. Materials and specifications are subject to change without notice. The International System of Units (SI) is used in this publication. CAT, CATERPILLAR, their respective logos, "Caterpillar Yellow", the "Power Edge" and Cat "Modern Hex" trade dress as well as corporate and product identity used herein, are trademarks of Caterpillar and may not be used without permission.

QTY	ENGINE CONNECTIONS	SIZE	SHEET
1	COOLANT DRAIN	ø19.1 [ø0.75] ID	2
1	EXHAUST	ø254.0 [ø10.00] OD	2

QTY	POSSIBLE TANK CONNECTIONS	SIZE	SHEET
1	FUEL FILLER	4" NPTF	3
2	SPARE PORTS	2" NPTF	3
1	MAIN TANK EMERGENCY VENT	5" NPTF	3
1	BASIN TANK EMERGENCY VENT	5" NPTF	3
1	NORMAL VENT	2" NPTF	3

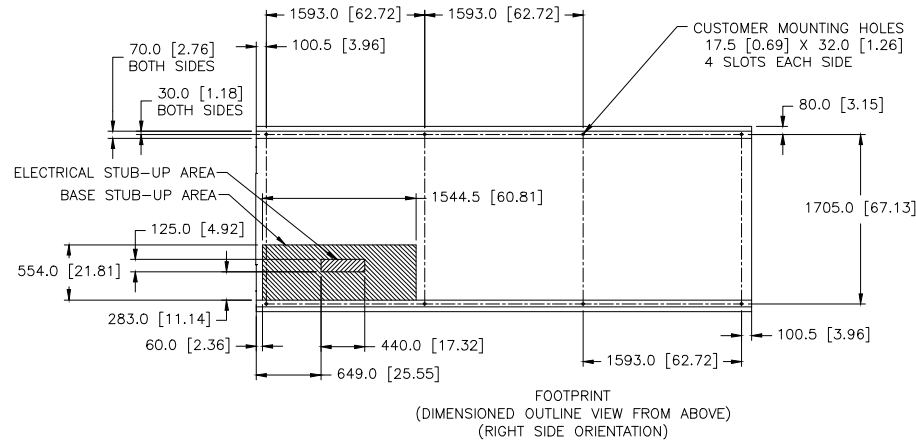
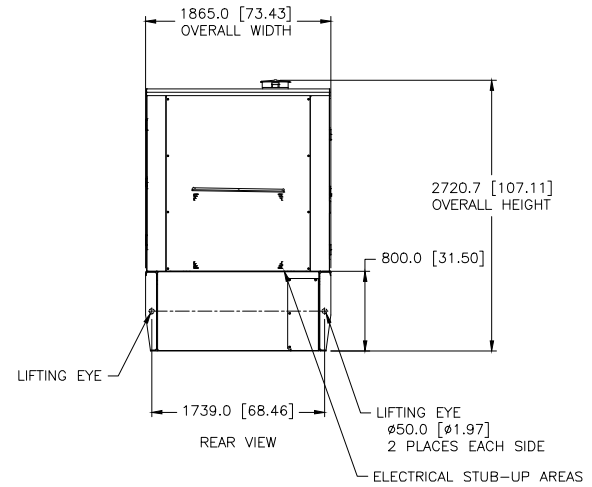
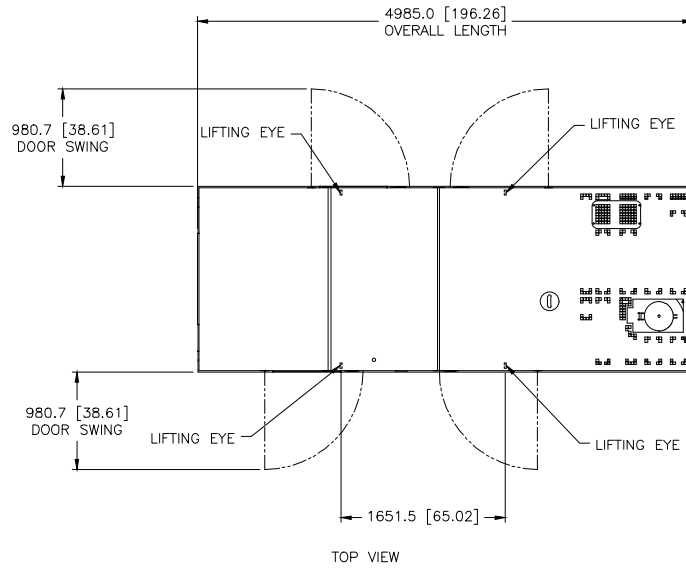

MODEL	TYPE	PRICING AR	TANK	ENCLOSURE
C18	-	LS-3981 CHG 00	LS-3872 CHG 00	LS-3860 CHG 00
		LS-3982 CHG 00		

PACKAGE LIFTED IN 4 PLACES
 PACKAGE SHOWN WITH MORE DETAIL ON SHEET 2

112968810000

1127381 DRAWING AUTO CAD

1120188 SWIRLING MARKINGS

11200136 CONFIDENTIALITY

11200137 INTEROPERATION

1120001 INTER & I/O

REV NO. 1

REV. DATE

DESIGNED BY: SWIFT

CHK. BY: SWIFT

APPROVED BY: MOUNTAIN LOY

DATE: 16 JUN 1999

RECORDS: IX

DATE OF THIS DRAWING: 22 AUG 1999

PROJECT: C18

SHEET NO. 1 OF 2

ENTERPLAN INC.

INSTALLATION COMPOSITE

C18 ENCL 24HR TANK

588-4128

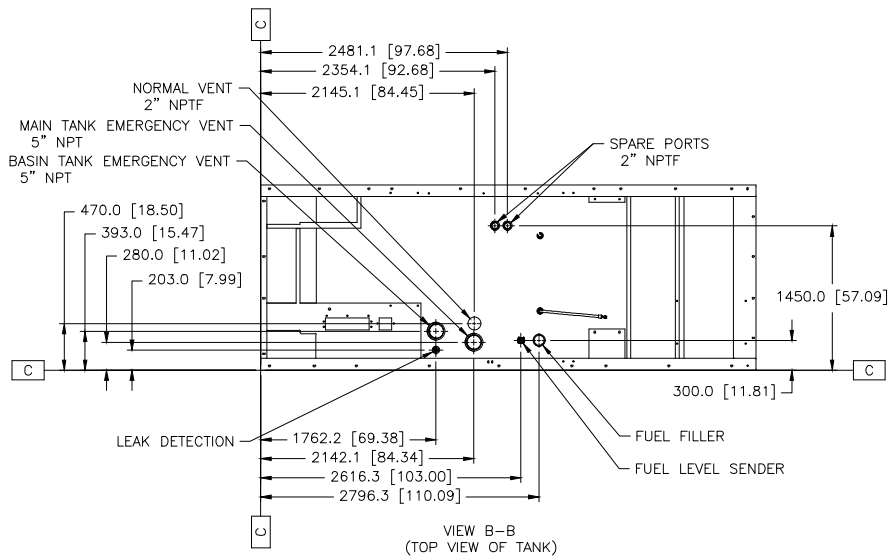
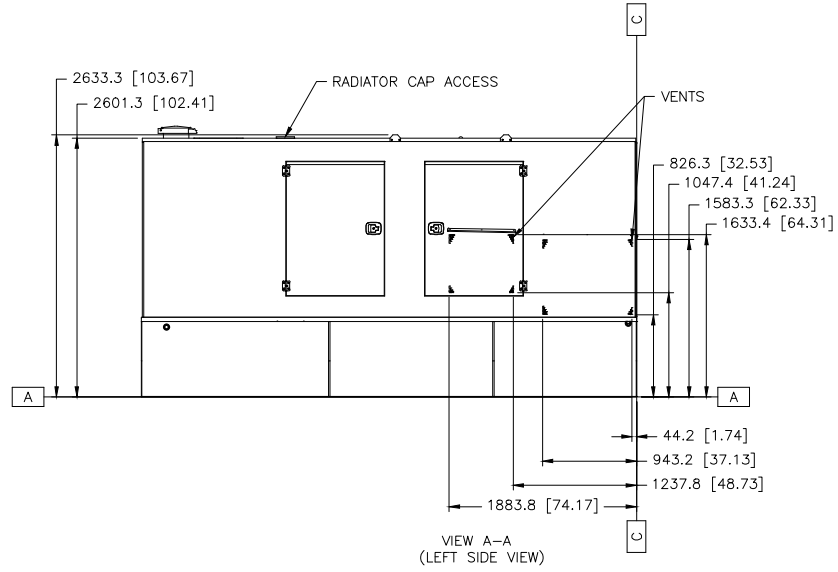

1	1C2968BIDENTY	
2	1E273X DRAWING - AUTOCAD	
3	1E019B SWIRL MARKINGS	
4	1E0013C1CONFIDENTIALITY	
5	1E012A131INTEROPERATION	
6	81E001 INTER & ID	
7		
8	DESIGNED BY	
9	DATE	
10	DRW. M.J. SWIFT	
11	DATE	
12	DESIGN N.C. MOULNLOY	
13	DATE	
14	RECORDS	
15		
16		
17		
18		
19		
20		
21		
22		
23		
24		
25		
26		
27		
28		
29		
30		
31		
32		
33		
34		
35		
36		
37		
38		
39		
40		
41		
42		
43		
44		
45		
46		
47		
48		
49		
50		
51		
52		
53		
54		
55		
56		
57		
58		
59		
60		
61		
62		
63		
64		
65		
66		
67		
68		
69		
70		
71		
72		
73		
74		
75		
76		
77		
78		
79		
80		
81		
82		
83		
84		
85		
86		
87		
88		
89		
90		
91		
92		
93		
94		
95		
96		
97		
98		
99		
100		

DATE 22AUG19
 SHEET 3 OF 3
CATERPILLAR INC.
 INSTALLATION - COMPOSITE
 C18 ENCL 24HR TANK
 588-4128

CONTROL SCHEMATIC (DSE 6310)

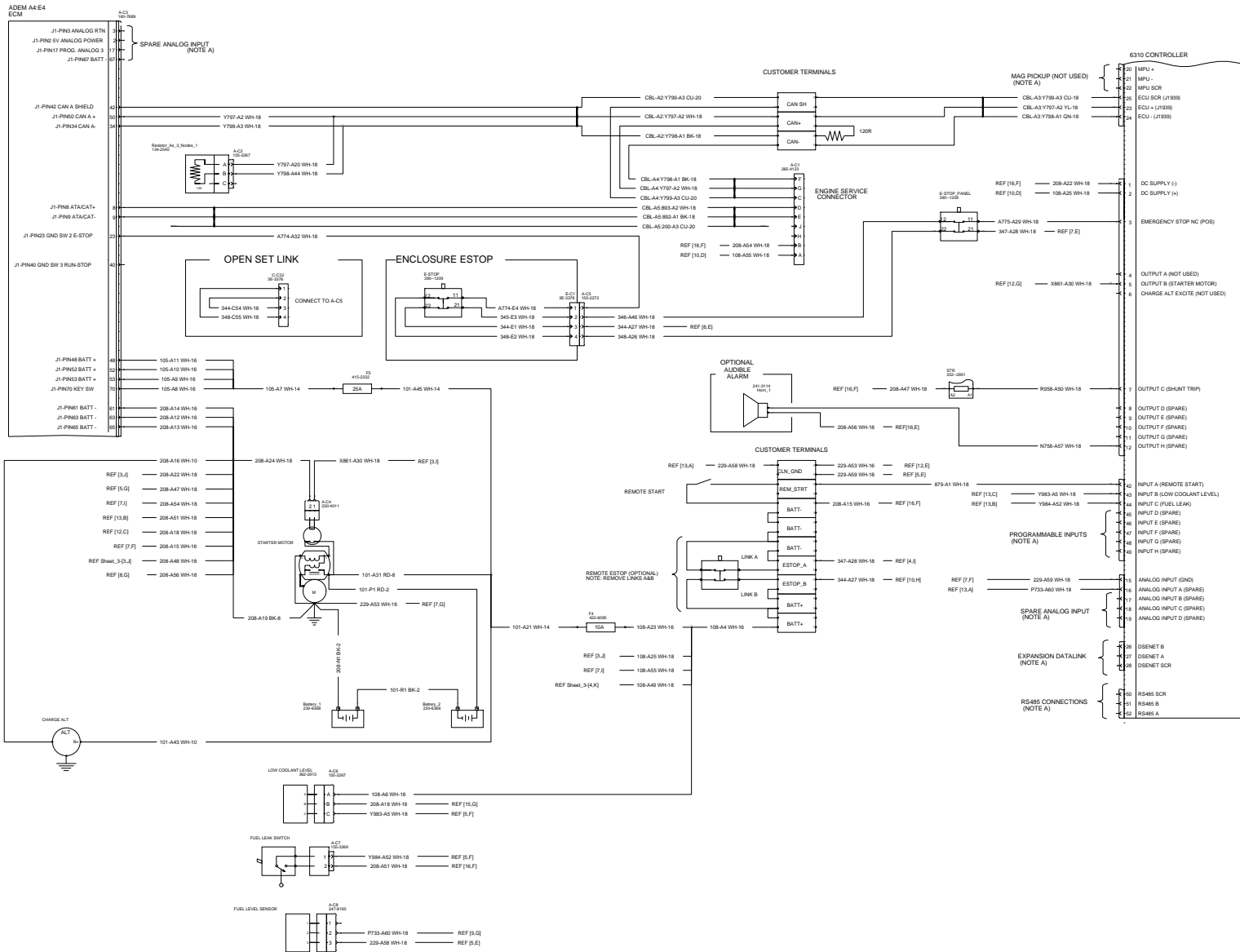

Terminal	Signal	Notes
25	MPU +	
26	MPU -	
27	MPU SCR	
28	ECU SCR (1939)	
29	ECU + (1939)	
30	ECU - (1939)	
31	DC SUPPLY (+)	
32	DC SUPPLY (-)	
33	EMERGENCY STOP NC (POS)	
34	OUTPUT A (NOT USED)	
35	OUTPUT B (STARTER MOTOR)	
36	CHARGE ALT EXCITE (NOT USED)	
37	OUTPUT C (SHUNT TRIP)	
38	OUTPUT D (SPARE)	
39	OUTPUT E (SPARE)	
40	OUTPUT F (SPARE)	
41	OUTPUT G (SPARE)	
42	OUTPUT H (SPARE)	
43	INPUT A (REMOTE START)	
44	INPUT B (LOW COOLANT LEVEL)	
45	INPUT C (FUEL LEAK)	
46	INPUT D (SPARE)	
47	INPUT E (SPARE)	
48	INPUT F (SPARE)	
49	INPUT G (SPARE)	
50	INPUT H (SPARE)	
51	ANALOG INPUT (GND)	
52	ANALOG INPUT A (SPARE)	
53	ANALOG INPUT B (SPARE)	
54	ANALOG INPUT C (SPARE)	
55	ANALOG INPUT D (SPARE)	
56	DSENET B	
57	DSENET A	
58	DSENET SCR	
59	RS485 SCR	
60	RS485 B	
61	RS485 A	

POWER SCHEMATIC

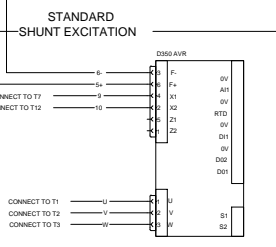
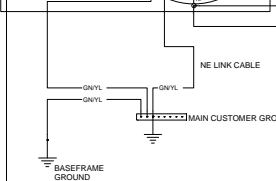
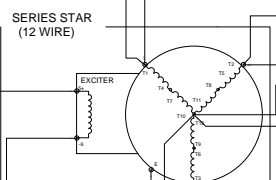
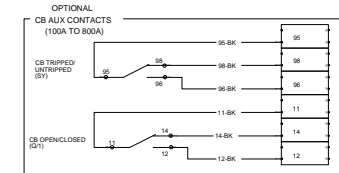
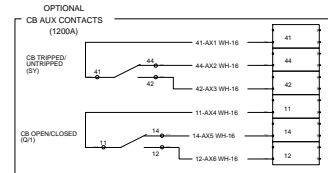
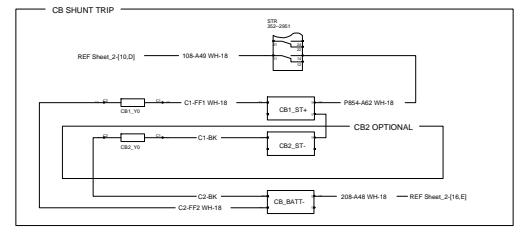
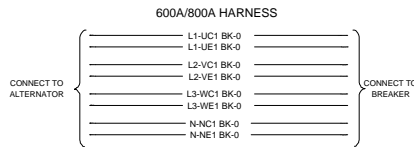
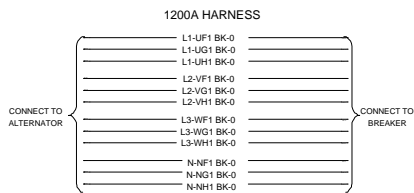
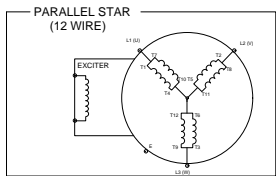
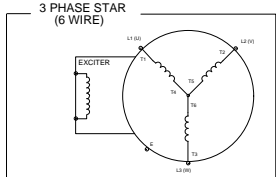

400A HARNESS

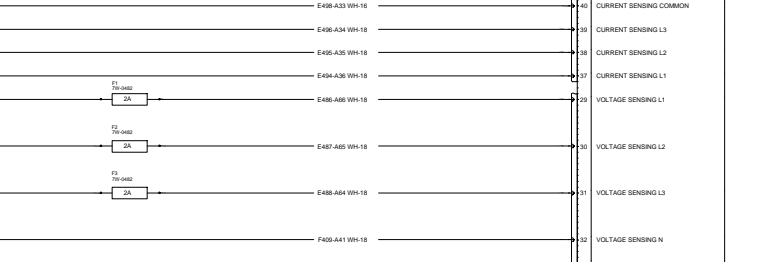
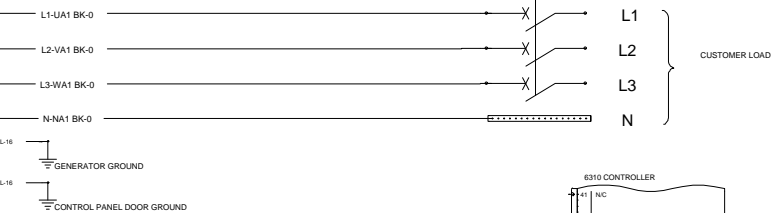

1	2	3	4	5	6	7	8	9	10	11	12	13	14	15	16	17	18	
19	20	21	22	23	24	25	26	27	28	29	30	31	32	33	34	35	36	37
38	39	40	41	42	43	44	45	46	47	48	49	50	51	52	53	54	55	56
57	58	59	60	61	62	63	64	65	66	67	68	69	70	71	72	73	74	75
76	77	78	79	80	81	82	83	84	85	86	87	88	89	90	91	92	93	94
95	96	97	98	99	100	101	102	103	104	105	106	107	108	109	110	111	112	113
114	115	116	117	118	119	120	121	122	123	124	125	126	127	128	129	130	131	132

ADDITIONAL OPTIONS

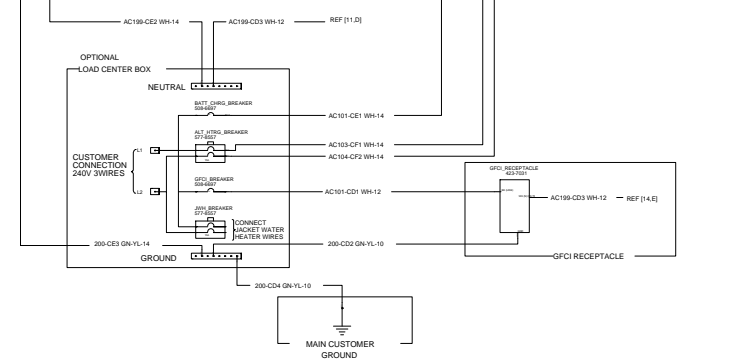
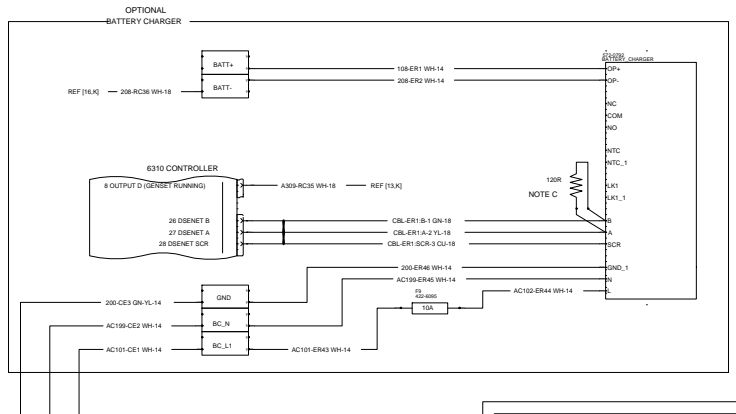
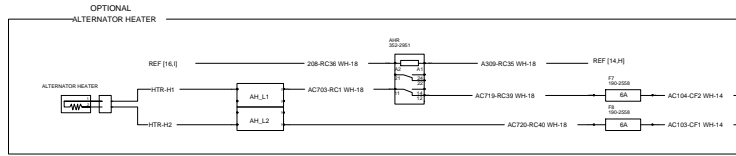

NO.	DESCRIPTION	DATE
1	ISSUED FOR CONSTRUCTION	10/15/14
2	REVISED TO ADD GFCI RECEPTACLE	11/10/14
3	REVISED TO ADD GFCI RECEPTACLE	11/10/14
4	REVISED TO ADD GFCI RECEPTACLE	11/10/14
5	REVISED TO ADD GFCI RECEPTACLE	11/10/14
6	REVISED TO ADD GFCI RECEPTACLE	11/10/14
7	REVISED TO ADD GFCI RECEPTACLE	11/10/14
8	REVISED TO ADD GFCI RECEPTACLE	11/10/14
9	REVISED TO ADD GFCI RECEPTACLE	11/10/14
10	REVISED TO ADD GFCI RECEPTACLE	11/10/14
11	REVISED TO ADD GFCI RECEPTACLE	11/10/14
12	REVISED TO ADD GFCI RECEPTACLE	11/10/14
13	REVISED TO ADD GFCI RECEPTACLE	11/10/14
14	REVISED TO ADD GFCI RECEPTACLE	11/10/14
15	REVISED TO ADD GFCI RECEPTACLE	11/10/14
16	REVISED TO ADD GFCI RECEPTACLE	11/10/14
17	REVISED TO ADD GFCI RECEPTACLE	11/10/14
18	REVISED TO ADD GFCI RECEPTACLE	11/10/14

